



TABLE OF CONTENTS

PROFESSIONAL RIVETING TECHNOLOGY XSERIES 4

XPac	11
XPress 800	8, 16
XPress Workstation	12
InduPac 1000	14
XTend	15
XPull	17
Sets of riveting tools	16
Short stroke cylinders	20
C-arms	21
Pull cylinders	22
Mouthpieces	24
Rivets	25
RivBoxes	27
Tool Boxes	28
Matrices Setting dies Extraction mandrels	32
Extensions Adapters Center Punch	33

RESISTANCE SPOT WELDING 34

InvertaSpot GT AUTOMATIC	37
VAS 6545A	38
C-Trafogun GT-V6	39
C-Arms	40
Electrode sets C-Trafogun	41
Electrodes	43
X-Trafogun GT-V6	44
Electrode sets X-Trafogun	45
Electrode caps	46
Airpuller AP95	47
Spot welding gun PSP - GT	48
Accessories PSP - GT	49
Accessories for InvertaSpot GT	51

WELDING TECHNOLOGY 54

InvertaPuls IP 7-2 ACT	60
InvertaPuls IP 6-2 ACT	62
InvertaPuls IP 4-2	64
InvertaPuls IP 4-3	65
IM 240-i	66
IM 240-3	67
WS TIG 200	68
Welding wires	70
Wire wheels & liner	72
Welding torches	73
Current nozzle / Gas nozzle	76
Stud welding devices	78
Welding studs	79
Flame coating	81
Aluminium crack testing agent	82
Temperature testing agent	82
Welding accessories	83
Vehicle protection & Occupational safety	84

SEPARATING TOOLS 86

MEC600	90
Body saws	93
Saw blades WPS 2000/3000	93
Files WPS 2000/3000 WPF 3000	95
Plasma Cutter WS 40i	96
Vario Drill WS90	97
Drilling tools	101
Milling cutters Drill bits	101
Laser-Cutter LC 04	104
Grinders	106
High speed burrs	106
Cut-off wheels grinding disks	107
File belts	108
Abrasive belts	108
Wire brushes	109

DENT REMOVAL TECHNOLOGY & METALWORKING 110

TRAC TOWER 550 with vacuum plate	113
Airpuller AP95	114
Work Station WS60	114
CBR Carbon Body Repair System	122
AluRepair Visar	123
AiroPower pneumatic press Standard-Kit	123
AiroPower Eco-Kit 19 pieces	123
CBR Gluing technology	124
Clamps	125
Vice Grips	126
Punch and Flange Pliers	127
Crimping pliers & seam opening pliers	128
Smart Repair	129
Dent removal lamps	130
Auto-Messfix	131
Bumping hammers	132
Dollies	133
Body spoons & pry bars	134
Files	134
Dolly WS 93 - Dent Removal Set	136
Fix-Cut	137
Scraper & deburring tools	137
Trim and mounting wedges	138
CBR 2109 Alluvial tin replacement	139
FlexiTherm Multi-Heatpad-System	140
2-component filler alu steel	141
Gas burners	142
Tinning	143
Hot air / heating devices	144
Cartridge guns	145
Fix magnets	146
Body line marking tool	147
WS WIPER tool kit	147

ROLL OUT 2000 148

Roll Out 2000® - Model 2020 CF	150
Roll Out 2000® - Model 2004	151
Upgrade Kit	151
Components	152
Separating & cutting tools	153
Auxiliary tools & protection	154
Storage & Special versions	155

WHEEL DOLLIES 156

Model overview	158
Sets	159
Spare parts	162

PAINTING EQUIPMENT & STORAGE SYSTEMS 164

PROLAQ WS	167
Spray Gun Washer WSM30 + Kit M	171
PDL-Liquid Cleaning fluid	171
Paint stands	172
Parts carts	173
Tool trolleys	174

SERVICE TOOLS 176

Lifting table WS Lifter 1.4T	179
Water Drain Cleaning Tool WDT-250	180

PROFESSIONAL WORKBAY SYSTEMS 182

Workbay WS ARENA	190
Welding protection curtain	192
LED-Lighting system	194
Mobile media supply	196
Stationary media supply	197
Vacuum systems	198
Accessories for vacuum systems	204
Bodyshop manager	205

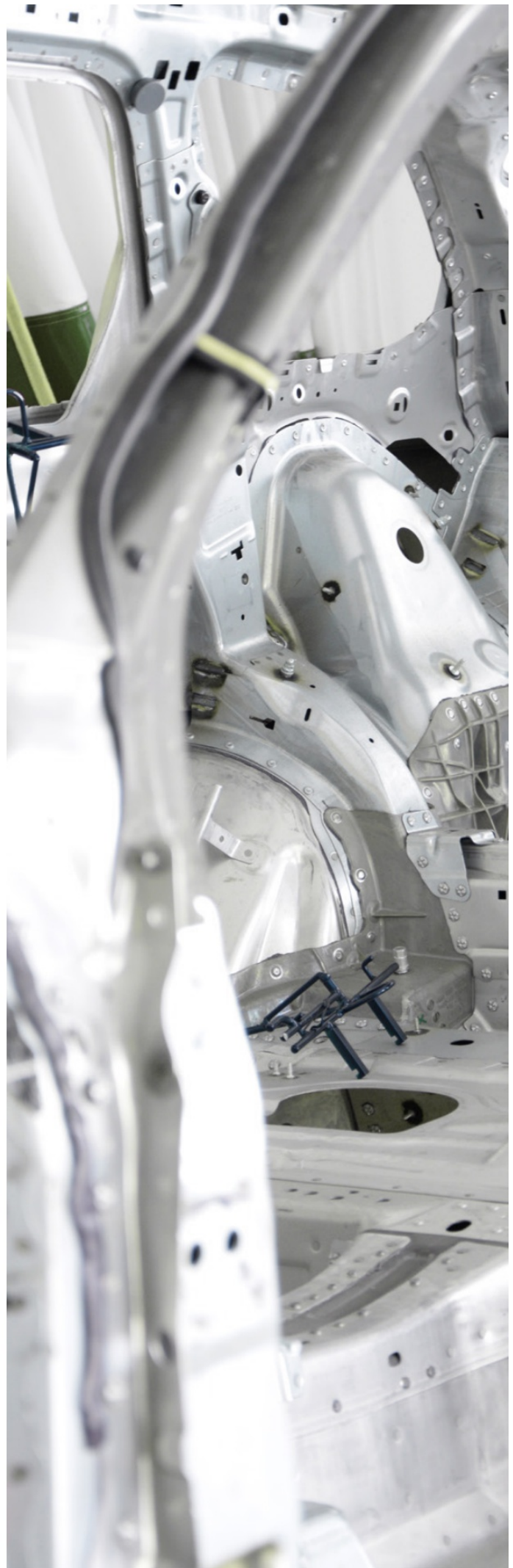

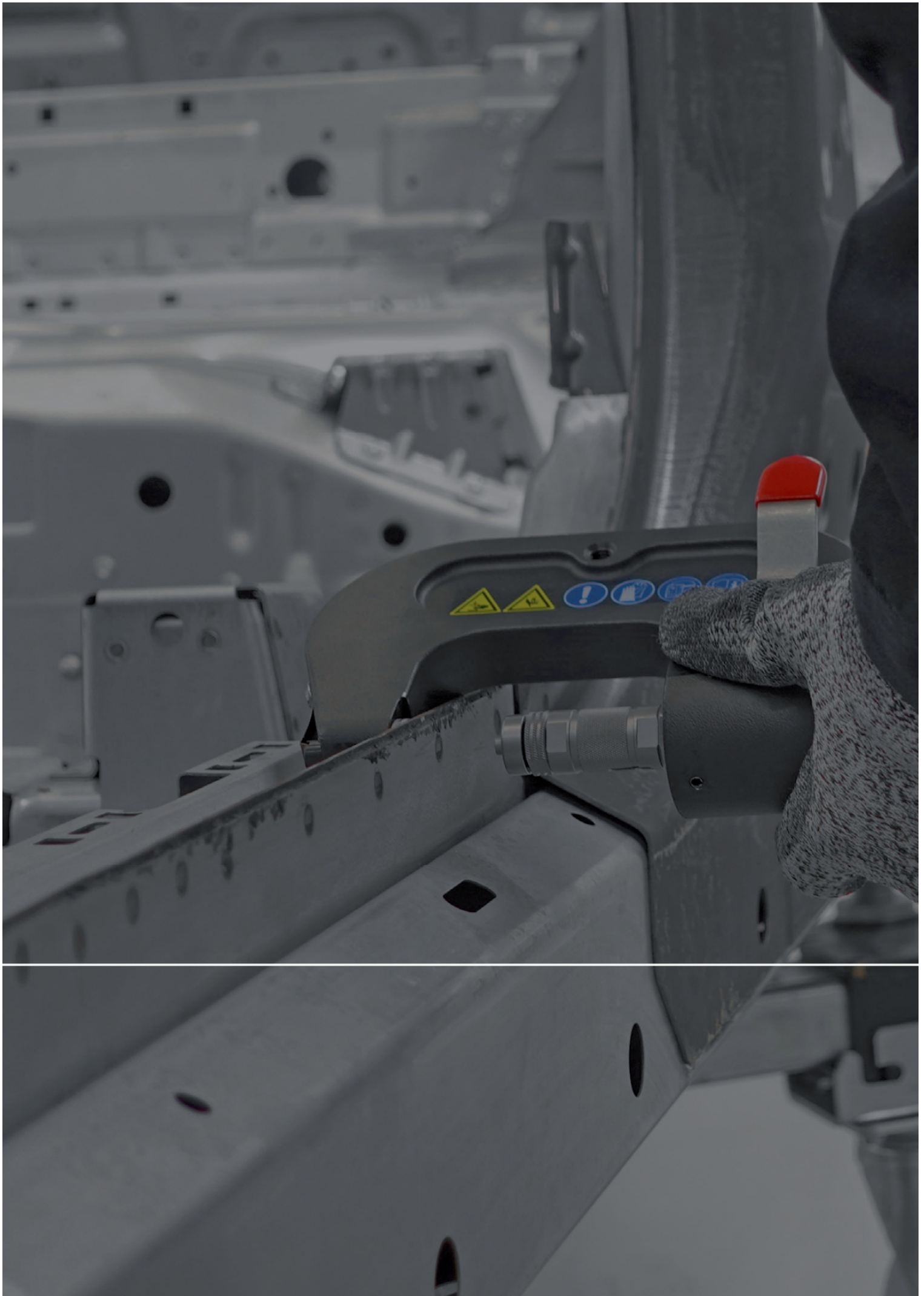



PROFESSIONAL
RIVETING TECHNOLOGY
XSERIES

XPress 800

XPress WORKSTATION

XPac

InduPac 1000

XTend

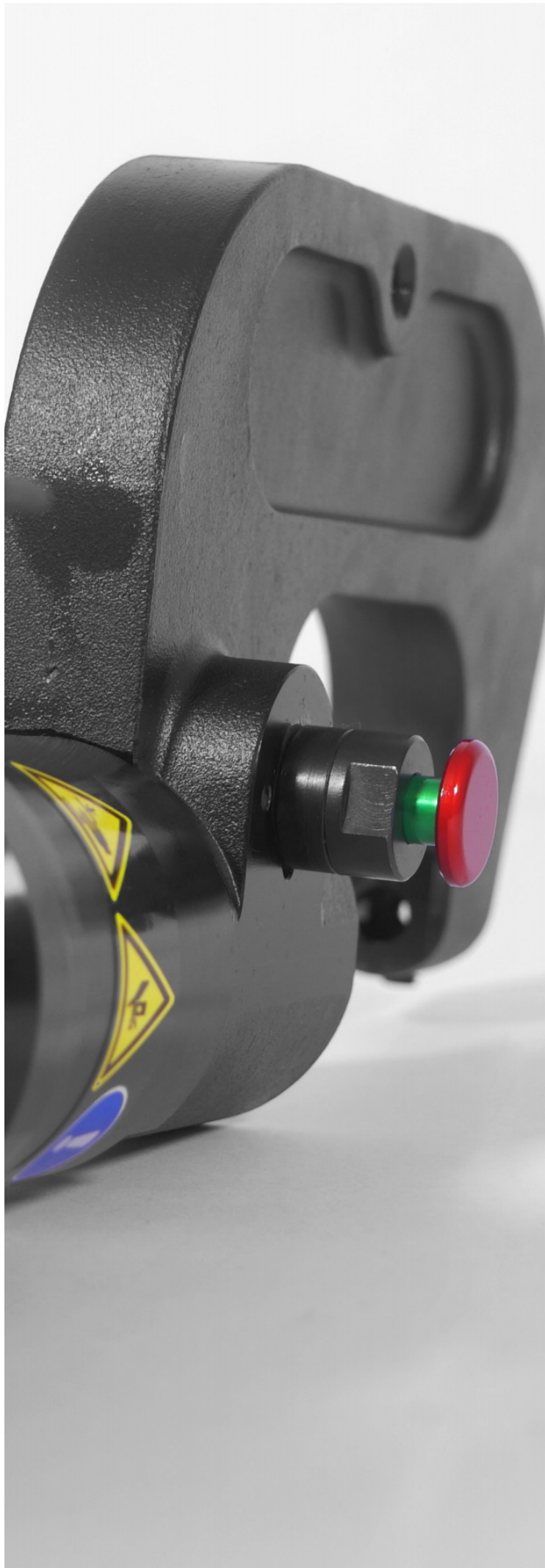

TABLE OF CONTENTS

XSeries riveting tools

XPress 800	8
XPac	11
XPress Workstation	12
InduPac 1000	14
XTend	15

Sets of riveting tools

XPress 800 Full Set	16
XPress 800 Basic Set	16
XPress 800 Standard Set	16
PushPull Upgrade-Kit	17
XPress trolley	17
XPull	17
XPress 800 PushPull Basic Set	18
XPress 800 PushPull Standard Set	18
XPress 800 PushPull Full Set	18
PushPull extension kit for self-piercing rivets	19

Accessories

Service Kit XPress	19
Face protection	19

Riveting tool modules

PowerPack XPress 800	20
----------------------	----

Short stroke cylinders

Short stroke cylinder SSC 35/25	20
Short stroke cylinder SSC 40/25	20
Short stroke cylinder PP90	20
C-arms	21

Pull cylinders

Blind rivet adapter BR20	22
Blind rivet adapter BR50	22
Blind rivet adapter BR80	22
Blind rivet nut adapter BRN50	23

Accessories for pull cylinders

Mouthpieces BR20/BR50	24
Blind rivet nuts for BRN50	25
Blind rivets	25

Accessories for short stroke cylinders

Self-piercing rivets	26
Flow-form rivets FFN	26
Countersunk flow-form rivets SFFN	26
Punching crowns SKR	27

RivBox-Assortment box

RivBox N°1 - Standard	27
RivBox N°2 - Mercedes-Benz	27
RivBox N°3 - General Motors	27

Riveting and punching tools

Tool Boxes	28
Matrices Setting dies Extraction mandrels	32
Extensions Adapters Centre punch	33

WS XSeries

THE PRODUCT FAMILY OF WS WIELÄNDER+SCHILL RIVETING TOOL TECHNOLOGY

MODULAR TECHNOLOGY

Enables the processing of different rivets with only one tool by using different adapters

HIGH PRESSING FORCE

Depending on the application and cylinder, high pressing forces can be achieved, such as those required for punching ultra-high strength steel

OPTIONALLY COMBINABLE

The adapters and dies are interchangeable within the **XSeries** product family

INDIVIDUAL TOOL SETS

The riveting system is supplemented by a large number of special tools for **customer-specific applications** for automotive production

HIGHEST QUALITY

Customer satisfaction is our top priority, therefore we pay attention to the best quality of our products

RELIABLE SERVICE

We offer fast and professional support by qualified personnel

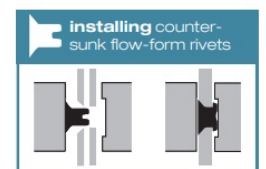
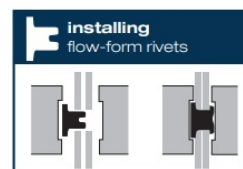
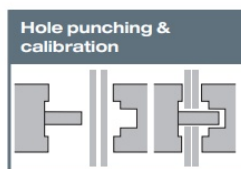
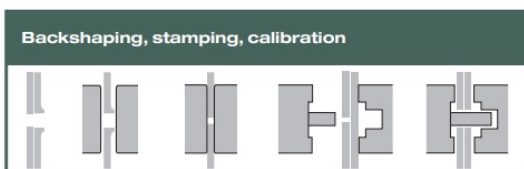
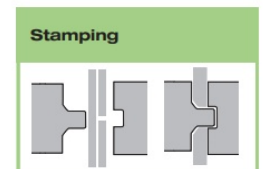
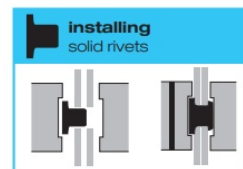
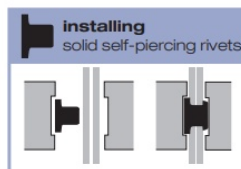
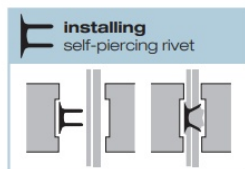
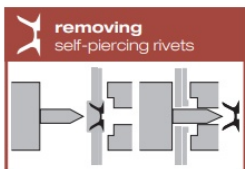

WS **X**Press 800

MODULAR RI- VETING SYSTEM



- Self-piercing rivets
- Flow-form rivets
- Countersunk flow-form rivets
- Solid rivets
- Solid self-piercing rivets
- Blind rivets
- Blind rivet nuts
- Blind rivet bolts
- Pressing out
- Backshaping
- Calibration
- Hole punching
- Stamping

**FOR PROCESS-SAFE
VEHICLE REPAIR**



pressing out

UHSS hole punching

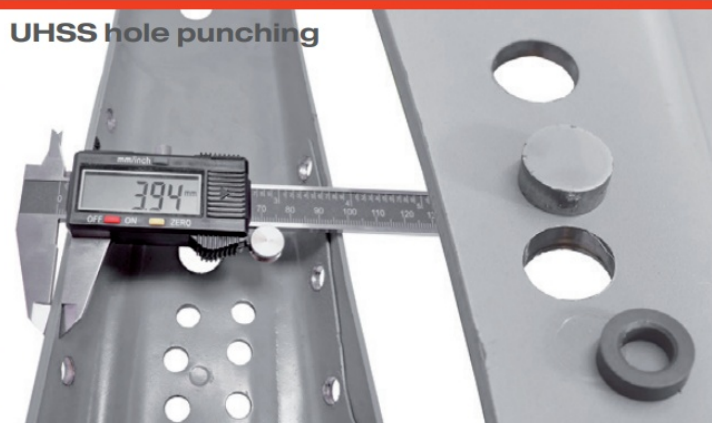

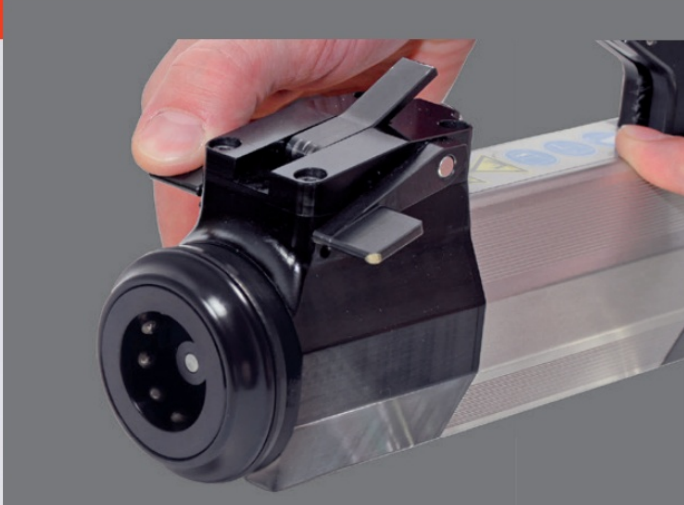

QUICK-STOP

The STOP button allows the currently coupled tool to be stopped in any position without releasing the pressure.



QUICK-LOCK



Quick and easy installation thanks to the quick-lock function. Replacement of the adapters by simply pressing the locking ring.



WITH INNOVATIVE PRESSURE CONTROL

TECH. SPECIFICATIONS



Countersunk flow-form rivets

Permissible hydraulic oil	Hydraulic oils acc. to DIN 51524 AFT oils acc. to DIN 51562-2 Type HLP 22 - HLP 36
Oil viscosity	approx. 22 - 36 mm ² /s at 40 °C
Oil filling quantity	90 cm ³
Air pressure max.	6 bar / 87 psi
compressed air	Quality class 2 (ISO 8573-1)
Temperature (ambient)	5 - 50 C° / 41 - 122°F
Prescribed safety clothing	Protective gloves and face protection
Emission sound pressure level	75 dB (A) LPAI
Emission sound pressure level	< 2.5 m/s ² (ISO/FDIS B662-11)



THE INNOVATION IN RIVETING TECHNOLOGY

The new compact XPac is a mechanically driven Hydraulic actuator which generates pressure forces up to **80 kN**.

XPac

SIMPLE HANDLING

The wireless mode of operation enables a significantly simplified work process.

DIRECT FORCE ADJUSTMENT

The automatic limit switch-off after reaching the set force guarantees a safe application.

QUICK ASSEMBLY

The XPac and the torque arm can be mounted quickly and easily on almost all standard cordless screwdrivers*.

VERSATILE APPLICATION

- Self-piercing rivets
- Flow-form rivets
- Countersunk flow-form rivets
- Solid self-piercing rivets
- Solid rivets
- Pressing out
- Backshaping
- Calibration
- Hole punching
- Stamping



Dimensions	240 x 62 x 130 mm
Height incl. torque bracket	290 mm
Weight kpl.	3.41 Kg
Oil volume	60 cm ³

Press force	25 kN - 80 kN
Cylinder stroke	25 mm
Required speed (<i>drive</i>)	1250 - 1500 rpm
Required torque	12.5 Nm

*with minimum technical requirements of a torque of > 12.5 Nm and a speed of 1250 - 1500 rpm

XPac Basic Set for self-piercing rivets

Item no. 703510

The following applications are possible with the basic set:

- installing self-piercing-rivets
- removing self-piercing-rivets

Scope of delivery:
 1 x **XPac** incl. torque bracket
 1 x C-arm GC 80/40
 1 x Tool Box **RS-03**
 1 x red handle
 1 x assembly/operating instructions



Note: Cordless screwdriver/drill is not included in delivery

modularly
expandable

TESTED &
 RECOMMENDED **by**
 JAGUAR LAND ROVER

Reg. N° JLRBSST006

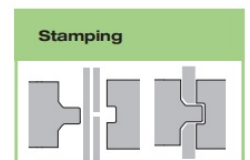
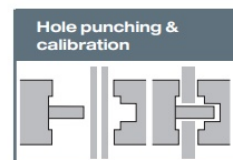
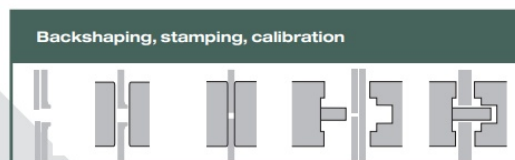
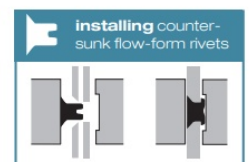
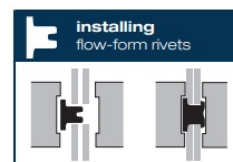
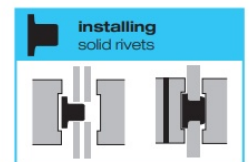
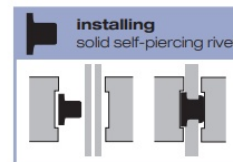
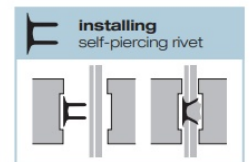
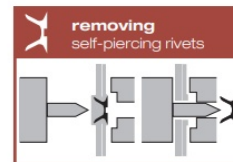



PRESSURE MONITORING SYSTEM WITH PATENTED **XLOGIC** TECHNOLOGY

The innovative system and the air tank integrated in the tubular frame of the trolley guarantee the user full process reliability* during riveting work on the vehicle. Even if the air supply is unexpectedly interrupted, the riveting process can be carried out safely*.

*Note: Process reliability during riveting is ensured by using the SSC 40 mm short-stroke cylinder. (included in delivery)

PROCESS-RELIABLE

guarantees full process reliability due to the **XLogic** pressure monitoring and the integrated air tank in the tubular frame

PNEUMOHYDRAULIC

100% COMPATIBLE

full compatibility with all modules of the XPress 800 system

HIGH TRACTION FORCE

Tensile force up to 80 kN*
Press force from 10 - 80 kN



Full Set

Item no. F700058

- 1 x Workstation incl. **XLogic**
- 1 x Short stroke cylinder SSC 40 mm
- 1 x XPress Power Pack
- 1 x blind rivet adapter BR 20
- 1 x blind rivet adapter BR 50
- 1 x Tool Box RS-06 V4 (JLR)
- 1 x blind rivet nut adapter BRN 50
- 1 x Tool Box RS-04 (BRN 50)
- 1 x C-arm GC 80/40
- 1 x C-arm GC 80/120
- 1 x C-arm GC 140/240
- 1 x spiral compressed air hose 4 m



Standard Set

Item no. S700058

- 1 x Workstation incl. **XLogic**
- 1 x Short stroke cylinder SSC 40 mm
- 1 x XPress Power Pack
- 1 x Tool Box RS-06 V4 (JLR)
- 1 x C-arm GC 80/40
- 1 x C-arm GC 80/120
- 1 x C-arm GC 140/240
- 1 x spiral compressed air hose 4 m

X WORKSTATION
Press



Upgrade Set

Item no. 700058

- 1 x Workstation incl. **XLogic**
- 1 x Short stroke cylinder SSC 40 mm
- 1 x spiral compressed air hose 4 m

FOR INDUSTRY AND AUTOMOTIVE TRADE



**FOR MANUAL AND
SEMI-AUTOMATIC PROCESSES**

**COMPACT
MODULAR
DURABLE
FAST
EFFICIENT
LOW MAINTENANCE**

The reliable, economical solution for

RIVETING PUNCHING STAMPING

and processing various joining elements

InduPac 1000

A new type of hydraulic supply station for industrial applications (e.g. riveting technology) where high forces are required via hydraulically driven tools.

The device was developed for continuous operation in industry and trade and is unrivalled on the market with the matching tools from the XSeries as pressure generators.

Production processes can be made more reliable and cheaper and the maintenance and operating costs are

reduced to a minimum because the InduPac 1000 has only one moving part.

These factors can influence the production process drastically reduce manufacturing costs.

TECH. DATA

Length	Width	Height	Weight	PB max
259 mm	56 mm	213 mm	2.65 kg	800 bar



CEILING SUSPENSION
ADAPTS TO ANY ENVIRONMENT
 TROLLEY
 STATIONARY

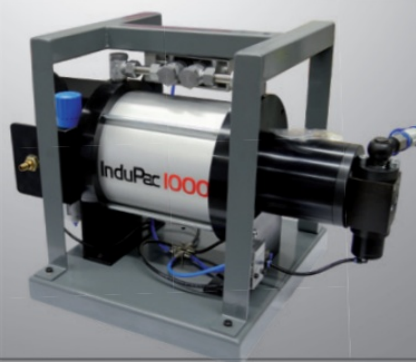

Indupac 1000 SC with XTend and trolley

Item no. 700055

For manual use of all XSeries components in Connection with the InduPac 1000

The „SC“ function divides the working process into 2 stages

„Positioning & Working“

InduPac 1000



XTend SC riveting tool

Item no. 700035

Adaptive riveting tool for stationary hydraulic-pneumatic pumps such as Indupac 1000 etc.

- Self-piercing rivets**
- Flow-form rivets**
- Countersunk flow-form rivets**
- Solid rivets**
- Solid self-piercing rivets**
- Blind rivets**
- Blind rivet nuts**

- Blind rivet bolts**
- Pressing out**
- Backshaping**
- Calibration**
- Hole punching**
- Stamping**

XTendSC



Weight	Hose length
2.60 kg	4.0 m

MATCHING MODULES & ACCESSORIES

from Page 20

XPress 800 Basic-Set

Item no. 700000

- installing self-piercing-rivets
- removing self-piercing-rivets

Scope of delivery:
 1 x Power Pack cpl.
 1 x short stroke cylinder SSC35/25
 1 x C-arm GC 80/40
 1 x Tool Box RS-03
 1 x transport case
 1 x operating instructions



XPress 800 Standard-Set

Item no. 700001

- installing self-piercing-rivets
- removing self-piercing-rivets

Scope of delivery:
 1 x Power Pack cpl.
 1 x short stroke cylinder SSC35/25
 1 x C-arm GC 80/40
 1 x C-arm GC 80/120
 1 x C-arm GC 140/240
 1 x Tool Box RS-03
 1 x transport case
 1 x operating instructions



XPress 800 - Full Set

Item no. 700002

- installing self-piercing-rivets
- removing self-piercing-rivets
- installing blind rivets
- installing blind rivet nuts

Scope of delivery:
 1 x Power Pack cpl.
 1 x short stroke cylinder SSC35/25
 1 x blind rivet adapter BR20
 1 x blind rivet adapter BR50
 1 x blind rivet nut adapter BRN50
 1 x C-arm GC 80/40
 1 x C-arm GC 80/120
 1 x arm GC 140/240
 1 x Tool Box RS-03
 1 x Tool Box RS-04
 1 x transport case
 1 x operating instructions



PushPull - Upgrade-Kit

Item no. 700004

An addition to existing XPress 800 Sets for:

- removing self-piercing-rivets
- installing flow-form rivets
- installing solid self-piercing rivets
- backshaping
- calibration
- hole punching

Scope of delivery:

- 1 x retraction cylinder PP90
- 1 x Tool Box RS-07
- 1 x operating instructions

PushPull



Tool trolley for XPress 800 riveting tools

Item no. 700010

- beech worktop - thickness 25 mm
- Full extension with soft closing
- Partially integrated handle strips
- 2 fixed and 2 swivel castors
- dimensions 770 x 650 x 795 mm



XPull - manual riveting tool

Item no. 700098

The XPull is a mechanical-hydraulic power amplifier which allows to generate a setting force of up to 20 kN with a mere hand force. The power transmission ratio is 1:8.

Furthermore, the XPull guarantees the use of all currently listed WS-tension adapters such as Tool Box RS-04.

Delivery including pulling adapter **M10** for blind rivet nuts with **left-hand thread**.

NEW



XPress 800 incl. PushPull

Item no. 700003 Basic Set

Modular riveting system with a force-supporting retraction cylinder for the installation of rivets in hard and ultra-hard structural parts and for:

- removing self-piercing-rivets
- installing flow-form rivets
- installing solid self-piercing rivets
- backshaping
- calibration
- hole punching

Scope of delivery:
 1 x Power Pack cpl.
 1 x retraction cylinder PP 90
 1 x C-arm GC 80/40
 1 x Tool Box RS-07
 1 x transport case
 1 x operating instructions

PushPull



tested and approved

Mercedes-Benz

XPress 800 incl. PushPull

Item no. 700006 Standard Set

Modular riveting system with a force-supporting retraction cylinder for the installation of rivets in hard and ultra-hard structural parts and for:

- removing self-piercing-rivets
- installing flow-form rivets
- installing solid self-piercing rivets
- backshaping
- calibration
- hole punching

Scope of delivery:
 1 x Power Pack cpl.
 1 x retraction cylinder PP 90
 1 x C-arm GC 80/40
 1 x C-arm bracket GC 80/120
 1 x C-arm bracket GC 140/240
 1 x Tool Box RS-07
 1 x transport case
 1 x operating instructions

PushPull



tested and approved

Mercedes-Benz

XPress 800 incl. PushPull

Item no. 700005 Full Set

Modular riveting system with a force-supporting retraction cylinder for the installation of rivets in hard and ultra-hard structural parts and for:

- removing self-piercing-rivets
- installing flow-form rivets
- installing solid self-piercing rivets
- backshaping
- calibration
- hole punching
- installing blind rivets
- installing blind rivet nuts

Scope of delivery:
 1 x Power Pack cpl.
 1 x retraction cylinder PP 90
 1 x blind rivet adapter BR 20
 1 x blind rivet adapter BR 50
 1 x blind rivet nut adapter BRN 50
 1 x C-arm GC 80/40
 1 x C-arm GC 80/120
 1 x C-arm GC 140/240
 1 x Tool Box RS-04
 1 x Tool Box RS-07
 1 x transport case
 1 x operating instructions

PushPull



tested and approved

Mercedes-Benz

PushPull - Extension kit for self-piercing rivets

Item no. 700009

The extension kit enables the processing of self-piercing rivets and the use of all Tool Boxes with already existing **PushPull**-Sets.

Scope of delivery:

- 1 x short stroke cylinder SSC35/25
- 1 x C-arm GC 80/40
- 1 x extension F1



Service Kit EB-XP 800

Item no. 700334

Venting and filling device for Power Pack XPress 800

Scope of delivery:

- 1 x special pump oiler (volume 250 ml)
- 1 x plug-in coupling
- 1 x filling port
- 1 x clear tube 6 x 4 mm
- 1 x clear tube 8 x 5 mm
- 1 x hydraulic oil HLP22 / PU 250 ml



Hydraulic oil HLP22

Item no. 700102 | 250 ml

XPress 800 - Special oil for the service and maintenance of the Power Pack, the blind rivet adapters and the **PushPull**.



ProtectSHIELD face protection

Item no. 881031

An uncompromising face protection that meets all requirements in terms of safety and ergonomics in a practical way 100%.

- patented visor attachment
- breathable headband
- wide field of view
- easy and fast head adjustment
- adjustment knobs are adjustable with gloves



Short stroke cylinders

Power Pack pneumatic-hydraulic

Item no. 700050

The Power Pack is a pneumatic-hydraulically driven pressure intensifier with a two-stage high-pressure pump. With a primary air pressure of 6 bar a hydraulic secondary pressure of 800 bar is generated.

Length	Width	Height	Weight	PB max.	Oil volume
259 mm	56 mm	213 mm	2.65 kg	800 bar	80 cm ³



Short stroke cylinder SSC 35/25

Item no. 700060

Stroke	Weight	PB max.	F max.
25 mm	1.4 kg	800 bar	77 kN



Short stroke cylinder SSC 40/25

Item no. 700067

First use: **Jaguar Land Rover - Workstation**

Stroke	Weight	PB max.	F max.
25 mm	1.68 kg	800 bar	100 kN



PushPull cylinder PP 90

Item no. 700105

Pressure cylinder with 2-way function: push and pull

Stroke	Weight	PB max.	F max.
16 mm	2.6 kg	800 bar	90 kN

PushPull



C-arms

Item no.	700070	700071	700072
Name	80/40	80/120	140/240
Operating window	80 × 40 mm	80 × 120 mm	140 × 240 mm
Weight	2 kg	4 kg	10 kg
	with safety interlock	with safety interlock	with safety interlock



C-arm set

Item no. 700080

Scope of delivery:

- 1 × C-arm GC 80/120
- 1 × C-arm GC 140/240
- 1 × extension 93 mm
- 1 × extension 60 mm
- 1 × transport case



Extension for C-arm 140/240

Name	for short stroke cylinder SSC 35/25	for PushPull cylinder PP 90
Item no.	700517	700153
Length	93 mm	60 mm



Pull cylinders

Blind rivet adapter **BR20**

Item no. 700100

PATENTED

SWIVEL JOINT

Our **smallest pulling adapter** for the global market!

Traction force 20 kN

- freely tiltable and rotatable
- for rivets with shaft: Ø 2.0-4.2 mm
- extremely good accessibility for challenging riveting tasks

Dimensions	Stroke	Weight	F max.	Swivel angle	interlock steps
100 x 56 x 74.5 mm	22 mm	1.0 kg	20 kN	120°	30°



incl. mouthpieces

Blind rivet adapter **BR50**

Item no. 700101

PATENTED

SWIVEL JOINT

The power package designed for the future!

Traction force 50 kN

- freely tiltable and rotatable
- for rivets with shaft: Ø 2.0-5.0 mm
- extremely good accessibility for challenging riveting tasks

Dimensions	Stroke	Weight	F max.	Swivel angle	interlock steps
252 x 56 mm	25 mm	1.5 kg	50 kN	120°	30°



incl. mouthpieces

Blind rivet adapter **BR80**

Item no. 700112

PATENTED

SWIVEL JOINT

The universal pull cylinder for multiple applications!

Traction force kN

- ultra high strength blind rivets and nuts
- HUK Bom
- studs
- bolts
- Magna Grip



Dimensions	Stroke	Weight	F max.	Swivel angle	interlock steps
200 x 112 mm	25 mm	2.5 kg	80 kN	120°	30°



SELECT THE MATCHING ADAPTER
ACCORDING TO YOUR NEEDS

Extensions & pulling adapters for BR50/BR 80

Item no.	Extensions		Pulling adapters			
	700150	700151	700138	700139	700136	700137
Name	BR 50	BR 50	BR 50	BR 50	BR 80	BR 80
Length	100 mm	150 mm	55 mm	55 mm	65 mm	65 mm
Ø	2.0 - 5.0 mm	2.0 - 5.0 mm	3.0 - 5.5 mm	5.5 - 7.0 mm	3.0 - 5.5 mm	5.5 - 7.0 mm

NEW



only for standard mouthpieces
of the BR 50

Blind rivet nut adapter **BRN50**

Item no. 700110

PATENTED

SWIVEL JOINT

With stepless variable pulling length adjustment!
 Traction force 50 kN

- perfect installation control
- freely rotatable and tiltable
- for riveting nuts M4-M12, threaded bolts, pins, etc.



Dimensions	Stroke	Weight	F max.	Swivel angle	interlock steps
241 x 56 mm	16 mm	1.65 kg	50 kN	120°	30°

Set - blind rivet nut adapter BRN50 incl. Tool Box RS-04

Item no. 700111

PATENTED

SWIVEL JOINT

Scope of delivery: Blind rivet nut adapter BRN 50 + Tool Box RS-04



Pulling adapter for blind rivet nuts for BRN50

Tool Box RS-04

	Item no.	Thread	Threadlength	
	700324	M4	25 mm	
	700325	M5	25 mm	
	700326	M6	30 mm	
	700327	M8	25 mm	
	700328	M10	25 mm	
	700305	M12	30 mm	
	700124	M10 <small>left-hand thread</small>	25 mm	
	700129	M12 x 1.5	30 mm	

Item no. 700201



Set of pulling adapters for blind rivet nuts consisting of: M4, M5, M6, M8, M10, M12

Pulling adapter for blind rivet studs for BRN50

Item no.	700127	700123	700122	700120	700121
Thread	5 mm RivBolt	6 mm RivBolt	M8	M6	self lock



Mouthpieces

Standard mouthpieces for BR20/BR50

for processing of blind rivets

Item no.	700204	700215	700524	700525	700532
Name	Tool Box (4 pcs.)	Tool Box (7 pcs.)	3.2 C	3.6 C	3-AL
Ø mm	3.2 - 4.5	3.2 - 5.1	3.2	3.6	
	3.2A 3.6A 4.0A 4.5A	3.2A 4.5B 3.6A 4.8B 4.0A 5.1B 4.5A	for blind rivets in the area of the roof rail	for blind rivets in the area of the roof rail	for blind rivets with extra long shaft
BR20	X		X	X	X
BR50	X	X	X	X	X



Standard mouthpieces for BR20/BR50

Item no.	flat head				concave head		
	700518	700519	700520	700521	700523	700522	700359
Name	3.2A	3.6A	4.0A	4.5A	4.5B	4.8B	5.1B
Ø mm	3.2	3.6	4.0	4.5	4.5	4.8	5.1
					for RIBE blind rivets	for RIBE blind rivets	
BR20	X	X	X	X			
BR50	X	X	X	X	X	X	X



Mouthpieces for additional pulling adapters for BR50/BR80 (page 22)

Item no.	for processing of blind rivets				extraction of self-piercing rivets with welding studs					
					for aluminum			for steel		
	703131	703132	703133	703134	703135	703137	703139	703136	703138	703140
Ø mm	5.1 - 5.5	4.5 - 5.1	4.0 - 4.5	3.4 - 4.0	3.0 - 4.0	4.0 - 5.0	6.0 - 6.5	3.0 - 4.0	4.0 - 5.0	6.0 - 6.5
BR50 3-5.5 mm	X	X	X	X	X	X		X	X	
BR50 5.5-7 mm							X			X
BR 80 3-5.5 mm	X	X	X	X	X	X		X	X	
BR 80 5.5-7 mm							X			X

NEW



color may vary

Blind rivet nuts for BRN50

Item no.	777203	777204	777205	777206	777207	777208
Name	M4	M5	M6	M8	M10	M12
Dimensions	6.0 × 11.0 mm	7.0 × 11.5 mm	9.0 × 15.5 mm	11.0 × 17.0 mm	12.0 × 17.5 mm	15.9 × 23.0 mm
Material	steel	steel	steel	steel	steel	steel
QTY	25 pcs.	25 pcs.	25 pcs.	10 pcs.	10 pcs.	5 pcs.



Rivet screws for BRN50

Item no.	777247	777267	777246
Name	M6	M8	SelfLock
Ø	6 mm	8 mm	6 mm
Material	steel	steel	steel
QTY	10 pcs.	10 pcs.	10 pcs.



Blind rivets

Item no.	777227	777228	777229	777231	777230	777215	777216	777217
Name	blind rivet 4 × 6	blind rivet 5 × 6	blind rivet 6 × 8	blind rivet 6 × 10	blind rivet RIBE	blind rivet AUDI	blind rivet BMW	blind rivet BMW
Dimensions	4.0 × 6.0 mm	5.0 × 6.0 mm	6.0 × 8.0 mm	6.0 × 10.0 mm	6.5 × 12.5 mm	6.5 × 15.0 mm	6.5 × 14.0 mm	6.5 × 16.0 mm
Material	aluminium	aluminium	aluminium	aluminium	galvanized	steel	steel	steel
BR20	X	X	X	X				
BR50	X	X	X	X	X	X	X	X
QTY	40 pcs.	40 pcs.	40 pcs.	40 pcs.	25 pcs.	10 pcs.	10 pcs.	10 pcs.



Note: When using Flow Form Rivets (FFN) and Countersunk Flow Form Rivets (SFFN), the description of the working process and the application areas of the corresponding repair instructions of the vehicle manufacturer (OEM) must be observed. In principle, a test rivet must always be installed whenever the material or the material thickness is changed. This is the only way to ensure a reliable riveting process. This applies to all rivets from the WS Wieländer+Schill range.



Self-piercing rivets

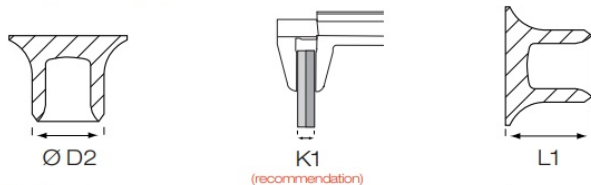

Ø D2	3.3 mm				5.3 mm							
Material	steel				steel							
L1 (mm)	3.5	4.0	5.0	6.0	4.0	5.0	6.0	6.5	7.0	7.5	8.0	9.0
K1 (mm)	1.5-2.5	2.5-3.5	3.0-4.0	4.0-5.0	2.0-3.0	3.0-4.0	4.0-5.0	4.5-5.5	5.0-6.0	5.5-6.5	6.0-7.0	7.0-8.0
Item no.	777218	777200	777225	777222	777202	777219	777221	777224	777226	777223	777201	777199
QTY	100 pcs.	100 pcs.	100 pcs.	100 pcs.	200 pcs.	100 pcs.	100 pcs.	100 pcs.	100 pcs.	100 pcs.	100 pcs.	100 pcs.

Flow-form rivets (10 pcs.)

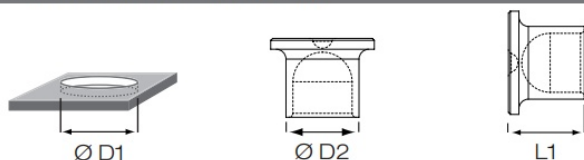

Ø D1	6.0 mm									
Ø D2	5.6 mm									
Material	steel							aluminium		
L1 (mm)	6.9	8.1	9.3	10.6	12.6	13.8	15.0	8.1	9.3	10.6
Name	S0	S1	S2	S3	S4	S5	S6	A1	A2	A3
Item no.	777232	777212	777213	777214	777233	777234	777235	777209	777210	777211

Ø D1	8.0 mm						
Ø D2	7.4 mm						
Material	steel						
L1 (mm)	8.0	9.2	10.4	11.4	12.6	13.8	15.0
Name	S08	S18	S28	S38	S48	S58	S68
Item no.	777260	777261	777262	777263	777264	777265	777266

Countersunk flow-form rivets (10 pcs.)

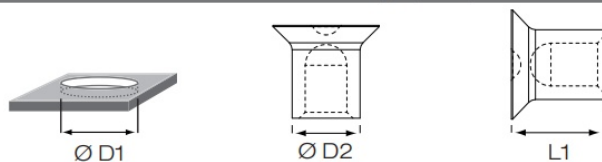

Ø D1	6.0 mm						
Ø D2	5.7 mm						
Material	steel						
L1 (mm)	5.8	7.8	9.0	10.1	11.5	12.9	13.9
Name	CS0	CS1	CS2	CS3	CS4	CS5	CS6
Item no.	777304	777300	777301	777302	777303	777305	777306



RivBox N° 1 - assortment box standard

Item no. 777281

Scope of delivery:

self-piercing rivets:

100 × 3.3 × 3.5 mm
 100 × 3.3 × 4.0 mm
 200 × 5.3 × 4.0 mm
 100 × 5.3 × 5.0 mm
 100 × 5.3 × 6.0 mm

flow-form rivets:

20 × ALU 5.6 × 8.1 mm A1
 10 × ALU 5.6 × 9.3 mm A2
 10 × ALU 5.6 × 10.6 mm A3
 10 × steel 5.6 × 8.1 mm S1
 10 × steel 5.6 × 9.3 mm S2
 10 × steel 5.6 × 10.6 mm S3

blind rivets:

40 × ALU 5.0 × 6.0 mm
 40 × ALU 6.0 × 8.0 mm
 20 × BMW 4.0 × 10.0 mm
 20 × BMW 4.0 × 12.0 mm
 20 × RIBE 6.5 × 12.5 mm

blind rivet nuts:

25 × steel M6 × 9.0 × 15.5 mm
 10 × steel M8 × 11.0 × 17.0 mm
 5 × steel M12 × 15.9 × 23.0 mm

1 × Special Center Punch

with 2 functions for self-piercing rivets



RivBox N° 2 - assortment box flow-form rivets

Item no. 777282

Scope of delivery:

flow-form rivets:

10 × FFN / FFR ALU 5.6 × 8.1 mm A1
 10 × FFN / FFR ALU 5.6 × 9.3 mm A2
 10 × FFN / FFR ALU 5.6 × 10.6 mm A3
 10 × FFN / FFR steel 5.6 × 8.1 mm S1
 10 × FFN / FFR steel 5.6 × 9.3 mm S2
 10 × FFN / FFR steel 5.6 × 10.6 mm S3
 10 × FFN / FFR steel 5.6 × 12.6 mm S4
 10 × FFN / FFR steel 5.6 × 13.8 mm S5
 10 × FFN / FFR steel 5.6 × 15.0 mm S6
 10 × FFN / FFR steel 7.4 × 8.0 mm S08
 10 × FFN / FFR steel 7.4 × 9.2 mm S18
 10 × FFN / FFR steel 7.4 × 10.4 mm S28
 10 × FFN / FFR steel 7.4 × 11.4 mm S38
 10 × FFN / FFR steel 7.4 × 12.6 mm S48
 10 × FFN / FFR steel 7.4 × 13.8 mm S58
 10 × FFN / FFR steel 7.4 × 15.0 mm S68



RivBox N° 3 - assortment box

Item no. 777283

Scope of delivery:

countersunk flow-form rivets:

50 × SFFN / CFFR CF0
 50 × SFFN / CFFR CF1
 50 × SFFN / CFFR CF2
 50 × SFFN / CFFR CF3
 50 × SFFN / CFFR CF4

flow-form rivets:

50 × FFN / FFR S0
 50 × FFN / FFR S1
 50 × FFN / FFR S2
 50 × FFN / FFR S3
 50 × FFN / FFR S4

1 × Special Center Punch

with 2 functions for self-piercing rivets



Punching crowns SKR

Ø mm	6.0	6.7	8.0
Item no.	700141	700142	700140
QTY	50 pcs.	50 pcs.	50 pcs.



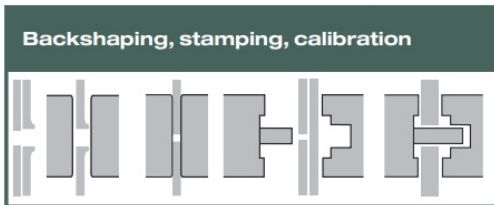
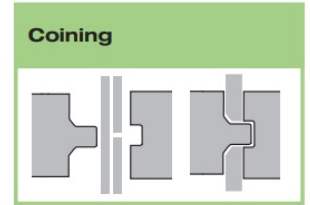
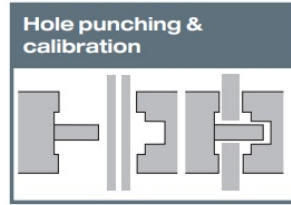
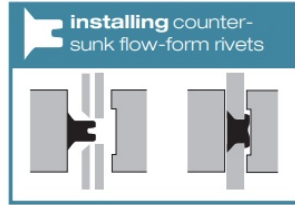
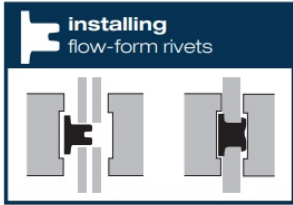
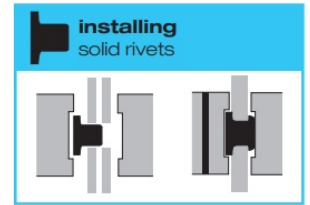
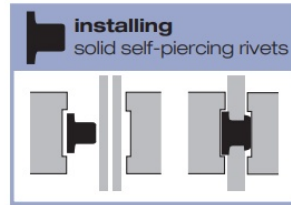
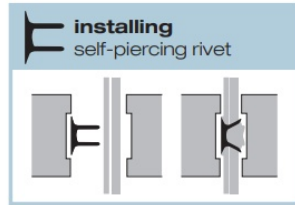
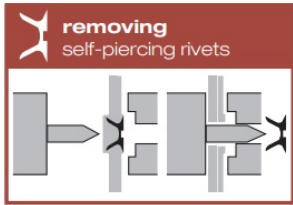

application videos



Tool Box RS-03

Item no. 700200

BMW

A1	A2	D1	D2	E1	E2
x1	x1	x1	x1	x1	x1
Ø 5.2 mm		Ø 3 mm		Ø 5 mm	

inclusive:
F1 Z4

SSC 35/25

SSC 40/25



Tool Box RS-05

Item no. 700202

AUDI

D3	D4	D13	D14	D18	D19	S1	S4	S5	D5
x1	x1	x1	x1	x1	x1	x1	x1	x1	x1
Ø 5 mm		Ø 5.3 x 7.5 mm			Ø 3.2 mm				5 mm

D12	D10	D11	D6	D7	D15	D16	D8	D9	D17
x1	x1	x1	x1	x1	x1	x1	x2	x1	x2
5 mm	Ø 4 mm		Ø 4.8 mm		Ø 6 mm		Ø 4 mm		6 mm

S2	S3	S6	S7	S8
x1	x1	x1	x1	x1
Ø 3.2 mm			Ø 5.3 mm	

inclusive:
F1 Z4

SSC 35/25

SSC 40/25

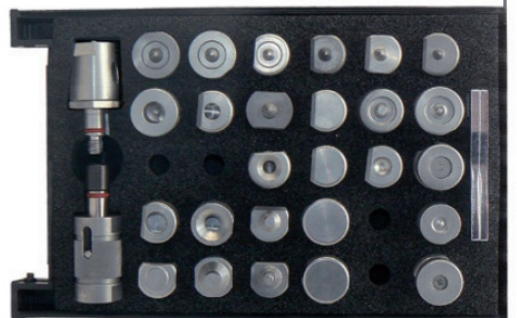

Tool Box Punch Kit | Ø 6.7 mm

Item no. 700143

K1	B67
x1	x1
Ø 6.7 mm	

inclusive:
SKR
6.7 mm

PushPull PP 90



Tool Box RS-06

Item no. 700193

JAGUAR LAND ROVER

A4	A6	BL6	C1	C2	C16	C17	C18	C21	E3
x1	x1	x1	x1	x1	x1	x1	x1	x1	x1
Ø 9 mm		6 mm	Ø 6 mm		6 mm		Ø 4.7 mm		

J1	K1	K2	K5
x2	x1	x1	x1
6 mm	Ø 6 mm		6 mm

inclusive:

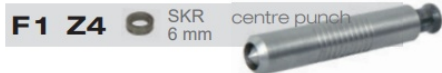

SSC 35/25

SSC 40/25



Tool Box RS-07

Item no. 700205

MERCEDES-BENZ

V1	V2	B3	B4	B7	G1	B5	B6	B8	G2
x1	x1	x1	x1	x1	x1	x1	x2	x1	x1
Ø 4 mm		Ø 6 mm				Ø 8 mm			

C1	C2	C3	C4	C5	K1	K2	K3	K4	A4
x1	x1	x1	x1	x1	x1	x1	x1	x1	x1
Ø 6 mm		Ø 8 mm		8 mm	Ø 6 mm		Ø 8 mm		

inclusive:



PushPull PP 90



Tool Box RS-08

Item no. 700206

TESLA

A4	B5	B6	B8	G2	C3	C4	C5	K3	K4
x1	x1	x1	x1	x1	x1	x1	x1	x1	x1
Ø 8 mm				Ø 8 mm			Ø 8 mm		

E1
x1
5.3mm

inclusive:

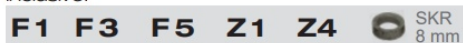

SSC 35/25

SSC 40/25

PushPull PP 90



Tool Box RS-09

Item no. 700195

FORD

A4	BL8	C10	C11	C12	C13	C14	C15	C19	C20
x1	x1	x1	x1	x1	x1	x1	x1	x1	x1
Ø 6 mm									

inclusive:

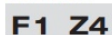

SSC 35/25

SSC 40/25



Tool Box RS-10

Item no. 700208

General Motors

A4	B6	C1	C2	C16	K5	B3	B4	B7	G1
x2	x1	x1	x1	x1	x1	x1	x2	x1	x1
Ø 8 mm		Ø 6 mm			6 mm	Ø 6 mm			

K1	K2
x2	x2
Ø 6 mm	

inclusive:

F3 Z1 Z4  SKR 6 mm

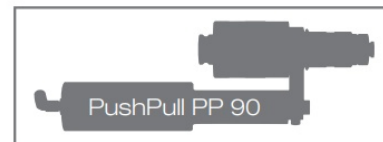

Tool Box RS-11

Item no. 700209

TESLA

E1	T1	T2	T3	T4	T5	T6	T7	T8
x1	x1	x1	x1	x1	x1	x1	x1	x1
Ø 5 mm								

inclusive:

F1 Z4



Tool Box RS-12



Item no. 700210

NIO

A5	B6	B3	B4	B7	G1	C1	C2	C16	K5
x1	x1	x1	x1	x1	x1	x1	x1	x1	x1
Ø 8 mm		Ø 6 mm			Ø 6 mm		6 mm	6 mm	

E1	E2	K1	K2
x1	x1	x1	x1
Ø 5 mm		Ø 6 mm	

inclusive:

F3 Z1 Z4  SKR 6 mm  SKR 8 mm 

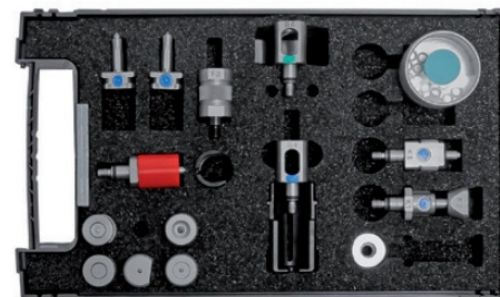
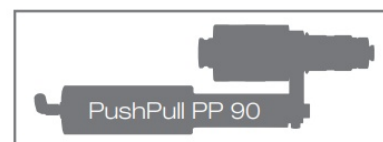

Tool Box RS-13

Item no. 700196

PORSCHE

A4	BL6	BL8	C1	C16	K1	K2
x1	x1	x1	x1	x1	x1	x1
6 mm		8 mm	Ø 6 mm		Ø 6 mm	

inclusive:

F1 Z4  SKR 6 mm



Tool Box RS-14 | self-piercing rivets add-on set

Item no. 700212

D1	D2	E1	E2
x1	x1	x1	x1
3 mm		5 mm	

inclusive:

F4 Z4

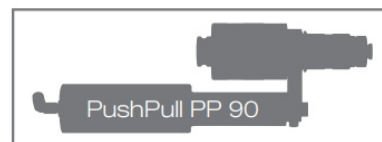

Tool Box RS-15

Item no. 700191

LUCID MOTORS

B3	B4	B7	G1	A5	B6	BL6	BL8
x1	x2	x1	x1	x2	x1	x1	x1
Ø 6 mm				Ø 8 mm	6 mm	8 mm	

C1	C2	C16	K1	K2	K5
x1	x1	x1	x1	x1	x1
Ø 6 mm	6 mm	Ø 6 mm	6 mm		

inclusive:

F1 F3 Z1 Z4



centre punch

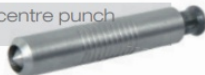

SSC 40/25

PushPull PP 90



Tool Box RS-16SSC

Item no. 700190

A4	BL8	C3	C4	C5	K3	K4
x1	x1	x1	x1	x1	x1	x1
8 mm		Ø 8 mm		Ø 8 mm		

inclusive:

F1 Z4

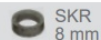

SSC 40/25



Tool Box RS-16PP

Item no. 700189

A4	B5	B6	B8	G2	K1	B67
x1	x1	x2	x1	x1	x1	x1
Ø 8 mm					Ø 6.7 mm	

C3	C4	C5	K3	K4
x1	x1	x1	x1	x1
Ø 8 mm		Ø 8 mm		





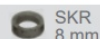
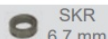













































inclusive:





























F3 Z1 Z4



PushPull PP 90



						4.7 mm	4.7 mm		
									
C10	C11	C12	C13	C14	C15	C17	C18	C19	C20
700537	700538	700541	700542	700539	700540	700891	703051	703226	703224
4.7 mm	3 mm	3 mm	5 mm	5 mm	4.7 mm	3.2 mm	3.2 mm	5.3 mm	5.3 x 5.5 mm
									
C21	D1	D2	E1	E2	E3	S2	S3	S6	S7
703232	700332	700262	700260	700261	700336	700233	700822	700821	700824
5.3 x 6.5 mm	5 mm	5 mm	5 mm	5 mm	5 mm	5 mm	5 mm	5 mm	4 mm
									
S8	T1	T2	T3	T4	T5	T6	T7	T8	D8
700823	700360	700366	700361	700362	700363	700364	700365	700367	700813
4 mm	6 mm	6 mm	6 mm	6 mm	6 mm	8 mm	8 mm	8 mm	4 mm
									
D9	D17	J1	C16	C1	C2	C3	C4	C5	V1
700811	700810	700248	700448	700256	700257	700266	700267	700276	700333
4 mm	5.2 mm	5.2 mm			9 mm	6 mm	8 mm	3.2-5.0 mm	5 mm
									
V2	A1	A2	A4	A5	A6	BL6	BL8	D3	D4
700277	700250	700251	700341	700369	700895	703222	703221	700800	700799

5.3 x 7.5 mm	5.3 x 7.5 mm	3.2 mm	3.2 mm	3.2 mm	5.3 x 5.5 mm	5.3 x 6.5 mm	6 mm	8 mm	5 mm
									
D13	D14	D18	D19	S1	S4	S5	B4	B6	D5
700812	700808	700804	700806	700795	700796	700798	700264	700270	700816
6 mm	6 mm	8 mm	6 mm	8 mm	6.7 mm	8 mm	6 mm	8 mm	4 mm
									
K5	B3	B5	B7	B8	B67	D12	G1	G2	D10
700449	700343	700344	700345	700342	700386	700820	700273	700268	700814
4 mm	4.8 mm	4.8 mm	6 mm	6 mm	6 mm	6 mm	8 mm	8 mm	
									
D11	D6	D7	D15	D16	K1	K2	K3	K4	
700335	700815	700806	700826	700809	700319	700297	700318	700298	

32 mm extension F1

Item no. 700220

for all riveting processes in combination with the **short-stroke cylinder SSC 35/25** **short-stroke cylinder SSC 40/25**



26 mm extension F3

Item no. 700337

for all riveting processes in combination with the **PushPull Zylinder PP90**



28 mm extension F4

Item no. 700442

for all riveting processes in combination with the **Tool Box RS-14**



28 mm adapter Böllhof F5

Item no. 700443

for all riveting processes in combination with the **Böllhof dies**



assembling tool Z4

Item no. 700299



coupling PushPull Z1

Item no. 700280

A coupling used to connect the punching dies **B3, B5, B7** and **B8** to the PushPull cylinder.



Special Center Punch with 2 functions

Item no. 628006

Function no 1: to mark the rivets at the top side of the rivet
Function no 2: to mark the rivets at the bottom side of the rivet
The special center punch is self-centering.





A close-up photograph of a control panel, likely for a resistance spot welding machine. The panel is a light beige or tan color. In the center, there is a prominent red diamond-shaped emergency stop button. To the left of the red button is a yellow triangular warning symbol. Below the red button is a small, circular indicator light. The panel has a slightly textured surface. The background is dark and out of focus.

RESISTANCE SPOT WELDING

TABLE OF CONTENTS

INVERTASPOT GT AUTOMATIC	37
VAS 6545A	38
C-Trafogun GT-V6	39
C-Arms	40
Electrode Sets C-Trafogun	41
Electrodes	43
x-Trafogun GT-V6	44
Electrode sets X-Trafogun	45
Electrode caps	46
Airpuller AP95	47
Spot welding gun PSP - GT	48
Accessories PSP - GT	49
Accessories for InvertaSpot GT AUTOMATIC	51

Version	Voltage	Item no.
WS version	400 V	471002
WS version	200 V	473002
WS version CN	400 V	471007
VAS 6545A	400 V	932160
VAS 6545A	200 V	932131
VAS 6545A version UL	200 V	932163
VAS 6545A version CN	400 V	932167
BMW version	400 V	932331
BMW version	200 V	932332
BMW version Active Cooling	400 V	932333
BMW version CN	400 V	932338
Citroën version	400 V	471002
Citroën version	200 V	473002
Ferrari version	400 V	471025
Ford version	400 V	932710
Ford version	200 V	932711
GM version	400 V	471002
GM version	200 V	473002
Honda version	400 V	933710
Honda version	200 V	933711
Hyundai version	400 V	471002
Hyundai version	200 V	473002
Jaguar version	400 V	471002
Jaguar version	200 V	473002
Mazda version	400 V	471002
Mazda version	200 V	473002
Mercedes-Benz version	400 V	932436
Mercedes-Benz version	200 V	932437
Mercedes-Benz version CN	400 V	471023
Opel version	400 V	932182
Opel version	200 V	932183
Peugeot version	400 V	471002
Peugeot version	200 V	473002
Renault version	400 V	471002
Renault version	200 V	473002
Tesla version	400 V	960750
Tesla version	200 V	960753
Tesla version UL	200 V	471019
Tesla version CN	400 V	960752
Vauxhall version	400 V	932182
Vauxhall version	200 V	932183
Huk-Coburg version	400 V	471031
Innovation Group version	400 V	471030

The scope of delivery is different for all versions!



TESTED AND
RECOMMENADED BY

ACURA
BMW
BUICK
CADILLAC
CHEVROLET
CITROËN
DACIA
FERRARI
FORD
GM
GMC
HONDA
HYUNDAI
JAGUAR LAND ROVER
KIA
MAYBACH
MAZDA
MERCEDES-BENZ
MINI
OPEL
PEUGEOT
RENAULT
ROLLS-ROYCE
SMART
TESLA
VAUXHALL

Resistance spot welding machine

The InvertaSpot GT-C AUTOMATIC is suitable for high and ultra high strength steels. It detects the conditions at the joining point, sets parameters automatically and monitors the welding process. Due to the full automation, it is extremely energy-efficient. Experts can still use the manual mode if necessary and set the parameters freely.

InvertaSpot GT
A U T O M A T I C

InvertaSpot GT AUTOMATIC

	Mains voltage
Item no. 471002	3 × 400 V
Item no. 473002	3 × 200-240 V

Scope of delivery:

1 × C-transformer gun 3 m	1 × 474250 set of allen key (4 + 5 mm)
1 × C-arm N° 1	1 × 497096 electrode cap A 32
1 × 474005 balancer bar streight	1 × 474028 Lateral hanger for C-arms
1 × 474013 balancer gibbet	1 × 478085 Holder for cable package
1 × 478060 balancer roller (cpl.)	1 × 478041 Suspension hook for power cable
1 × 498085 spring balancer	1 × 474007 Wheel set incl. screws
1 × 474017 insolation strap	1 × Instruction manual





**SAVING OF INDIVIDUAL
WELDING PARAMETERS**





**DOCUMENTING AND
MANAGING OF JOB
DATA**

**MATERIAL
RECOGNITION**

SOFTWARE UPDATES

**CURRENT CONTROL
AND PRESSURE
MONITORING**



-  Energy-efficient
-  Time saving
-  Software updates
-  Best service
-  Local support

Resistance spot welder

The VAS 6545A resistance spot welder can be used to carry out all approved repair welds on Volkswagen Group vehicles. The welding parameters are set using simple, self-explanatory symbols. The welding programmes are for high-strength and ultra high-strength sheet metal, for adhesive spot-welded joints and for galvanised sheet metal.

VAS 6545A

VAS 6545A	ASE Number	Mains voltage
Item no. 932160	ASE 437 075 01 000	3 x 400 V
Item no. 932161	ASE 437 075 00 023	3 x 200-240 V

Accessory set 7 pieces

VAS 6545A/1	ASE Nummer
Item no. 932110	ASE 437 075 01 000

Accessory set for the resistance spot welder VAS 6545A for device protection and for extending the application range of spot welding.

- Scope of delivery:
- 1 x Cover for InvertaSpot GT
 - 1 x Raising & wheel spacer set
 - 1 x Electrode set N° 7 for C-arm N° 1 cap size 16; 90°
 - 1 x C-arm N° 4 with electrode 260 mm; cap size 16
 - 1 x Electrode 170 mm, for C-arm N° 4 cap size 16
 - 1 x Electrode cap remover
 - 1 x Abrasive sponge grain 60



- Scope of delivery:
- 1 x Control unit with water tank 80 l
 - 1 x C-trafogan 3 m
 - 1 x C-arm N° 1
 - 1 x C-arm set N° 3 + E-set 90°
 - 1 x Suspension unit with spring balancer
 - 1 x Hanger for C-arms
 - 1 x Instruction manual





AUTOMATIC FUNCTION

PROCESS CONTROL

**ELECTRONIC DISTANCE
MEASUREMENT**

**WATER COOLING UP TO
THE ELECTRODE CAPS**

**LARGE OPENING
ANGLE**

The transformer gun was developed under strict EN standards and corresponds to the latest technological state of safety. The electrode lock with water stop when changing the arms provides additional safety and comfort. With the numerous electrode arms and the extensive range of accessories, no wishes are left unfulfilled - but special designs are also possible on request.

C-TRAFOGUN GT-V6

C-Trafogun GT-V6

Item no. 474466

Scope of delivery:

- 1 x C-trafogun 3 m
- 1 x C-arm N° 1
- 1 x Electrode caps I type A-32
- 1 x Suspension hook
- 1 x Rotation ring



Cable bundle length	L x W x H	Weight	Adjustment range	Welding current	Electrode pressure	Mark of conformity
Standard: 3 m up to 6 m possible	600 x 100 x 320 mm	15 kg	0-13 kVA	max. 13 kA	max. 6.2 N	CE/UL/CCC depending on version



C-Arms

C-Arm N° 1 | standard

Item no. 495620

Electrodes	Electrode caps
C-electrode curved	Ø 16 mm

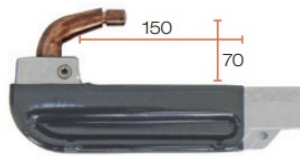

C-Arm N° 2 | for wheel arches

Item no. 495602

Electrodes	Electrode caps
Electrode A Mushroom shape Electrode B Spoon shape	Ø 13 mm

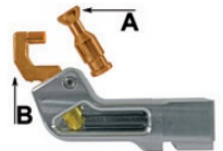

C-Arm N° 3

Item no. 495625

Electrodes	Electrode caps
C-Electrode curved	Ø 16 mm

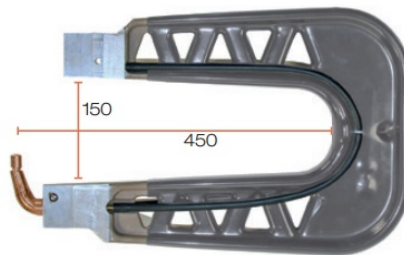

C-Arm N° 4

Item no. 495615

Electrodes	Electrode caps
Electrode 260 mm Electrode holder	Ø 16 mm

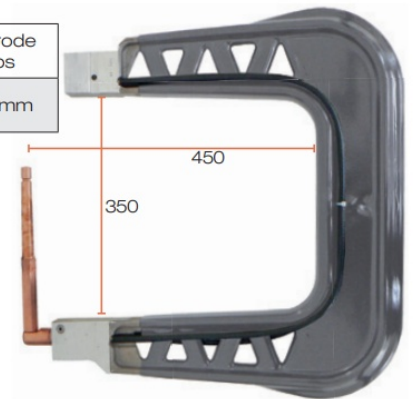

C-Arm N° 5

Item no. 495626

Electrodes	Electrode caps
C-Electrode curved Electrode 135 mm Copper sealing washer	Ø 16 mm

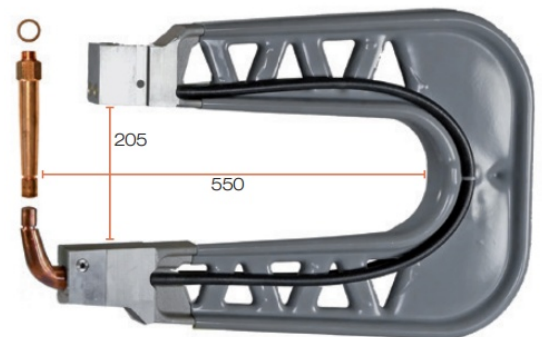

C-Arm N° 6

Item no. 495611

Electrodes	Electrode caps
Electrode 46 mm Electrode holder	Ø 16 mm

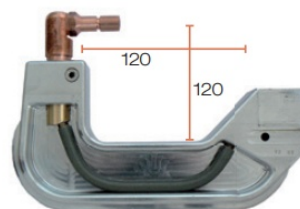

C-Arm N° 7

Item no. 495650

Electrodes	Electrode caps
Electrode 83 mm Electrode holder	Ø 16 mm



C-Arm Set | C-Arm N° 2 + N° 3

Item no. 495630

Electrodes	Electrode caps
C-Electrode curved Electrode A Mushroom shape Electrode B Spoon shape	Ø 16 mm

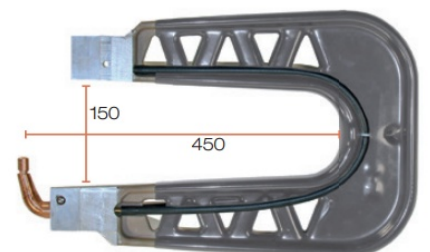
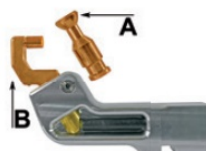

C-Arm Electrode attachment with rocker „Passat“

Item no. 495664

For C-arm N° 1

Electrode set with rocker for welding very narrow strips of sheet metal, e.g. on the VW Passat. Due to the concentric electrodes, which move the welding spot from the centre to the outside, you can reach every corner.

Full functionality of the automatic mode guaranteed.

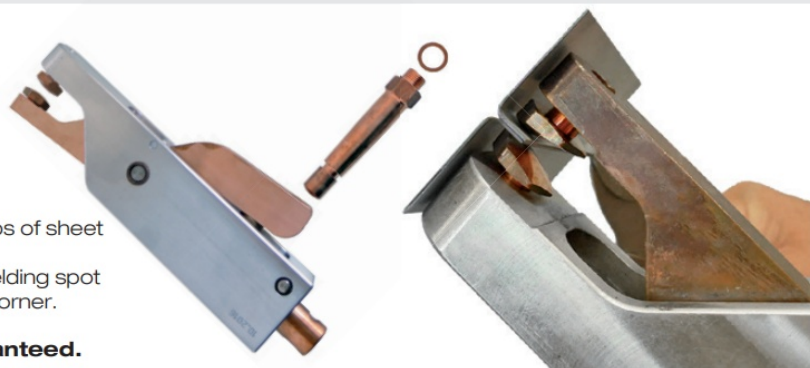

Electrodes hexagonal

Item no. 495669

QTY: 2 pcs.



Electrodes concentric

Item no. 495679

QTY: 2 pcs.



C-Arm Electrode attachment with rocker N° 10 | for wheel arches

Item no. 495604

For C-arm N° 1

Electrode set with rocker for easier welding of wheel arches. For all repair/welding tasks where there is no accessibility with conventional electrodes.

Full functionality of the automatic mode guaranteed.



Electrode flat

Item no. 495659



Electrode F | finger shape

Item no. 497073



Electrode Set N° 7 | 90° angle

Item no. 495607

For C-Arm N° 1

Electrodes	Electrode caps
Electrode 149 mm curved Electrode short curved Electrode holder	Ø 16 mm



Electrode 149 mm | curved

Item no. 495676



Electrode short | curved

Item no. 495695



Electrode Set N° 9 | 38° angle

Item no. 495645

For C-Arm N° 1

Electrodes	Electrode caps
Electrode bent 38° long Electrode bent 38° short Electrode holder	Ø 16 mm



Electrode Set N° 12 | 38° angle

Item no. 495646

For C-Arm N° 1

Electrodes	Electrode caps
Electrode bent 38° long Electrode bent 38° short	Ø 16 mm



Electrode bent 38° | long

Item no. 495677



Electrode holder for Set N° 7 & N° 9

Item no. 495627



Screw bolt for electrode set N°7

Item no. 495693



O-rings for screw bolt

Item no. 495694

QTY: 3 pcs.



Electrode Set N° 11 | 90° angle

Item no. 495606

For C-Arm N° 1

Electrodes	Electrode caps
Electrode 121 mm Electrode 28 mm	Ø 16 mm



Electrode 28 mm

Item no. 495623











Electrode 121 mm

Item no. 495622



Electrodes

Length	Shape	Suitable for C-Arm							Item no.
		N° 1	N° 2	N° 3	N° 4	N° 5	N° 6	N° 7	
46 mm	straight 						•		495621
83 mm	straight Standard electrode on gun side 				•			•	495617
135	straight 					•			495667
170	straight 				•				495619
260	straight 				•				495616
	c-shape curved 	•		•		•			495635
	Shape A Mushroom 		•						497070
	Shape B Spoon 		•						497072

Electrode Set for C-Arm N° 4

Item no. 495618

QTY: 2 pcs.



Electrode holder

Item no. 495692

suitable for:

- C-Arm N° 4
- C-Arm N° 6
- C-Arm N° 7



Copper sealing washers M16

Item no. 494040

QTY: 2 pcs.



**HIGH ACCESSIBILITY IN
NARROW PLACES**

**PARTICULARLY LIGHT
AND EASY TO HANDLE**

**WATER COOLING UP TO
THE ELECTRODE CAPS**

1-BUTTON OPERATION



X-TRAFOGUN GT-V6

The transformer gun was developed under strict EN standards and corresponds to the latest technological state of safety. With the numerous electrode arms and the extensive range of accessories, no wishes are left unfulfilled - but special designs are also possible on request.

X-Trafogun GT-V6

Item no. 474402

Scope of delivery:

- 1 x X-Trafogun 3 m
- 1 x Electrode Set N° 69
- 1 x Suspension bracket
- 1 x Integrated vertical suspension plate



Cable bundle length	L x W x H	Weight	Adjustment range	Welding current	Electrode pressure	Mark of conformity
Standard: 3 m up to 6 m possible	600 x 100 x 320 mm	15 kg	0-13 kVA	max. 13 kA	max. 6.2 N	CE/UL/CCC depending on version



Electrode Set N° 50 | straight 90°

Item no. 495715

Diameter	Length
16 mm	280 mm



Electrode Set N° 51 | straight 90°

Item no. 495750

Diameter	Length
16 mm	420 mm



Electrode Set N° 59 | cranked

Item no. 495740

Diameter	Length
16 mm	280 mm



Electrode Set N° 65

Item no. 495800

Diameter	Length
16 mm	280 mm



Electrode Set N° 66 | standard

Item no. 495805

Diameter	Length
16 mm	260 mm



Electrode Set N° 67 | pointed shape

Item no. 495815

Diameter	Length
16 mm	260 mm



Electrode Set N° 68 | for wheel arches

Item no. 495065

Not water cooled



Angle Electrode | E-set N° 68

Item no. 497040



Electrode Isotube | E-set N° 68

Item no. 497041

Diameter
14 mm



Electrode Set N° 69 | standard

Item no. 495820

Diameter	Length
16 mm	120 mm



Electrode Set N° 72 | Sprinter | Astra

Item no. 495082

Diameter	Length
13 mm	120 mm



Electrode caps | E-set N° 72 | round

Item no. 497086

QTY: 3 psc.



Electrode Caps

Ø 13 mm

Type	F round	Spade shape long	A R32	straight	straight	sloped R20	E	D
Length	18 mm	23 mm	18 mm	19.5 mm	24 mm	16.5 mm	18 mm	18 mm
Suitable for					X-gun E-Set no. 74	X-gun E-Set no. 70		
QTY	6 pcs.	6 pcs.	6 pcs.	6 pcs.	6 pcs.	6 pcs.	4 pcs.	4 pcs.
Item no.	497001	497004	497005	497006	497007	497008	497016	497018



	Ø 12 mm	Ø 12 mm					
Type	ball	sloped		round	short		
Length	18 mm	18 mm		18.5 mm	16 mm		
Suitable for	Multi Spot I 297106	Multi Spot		X-gun E-Set no. 72	X-gun E-Set no. 73		
QTY	6 pcs.	6 pcs.		3 pcs.	3 pcs.		
Item no.	297121	297122		497086	497009		



Ø 16 mm

Type	A-32	B conical-flat	H Spade shape	E	A-40 R 40	D conical-flat	F round	P eccentric	D 38°
Length	20 mm	20 mm		20 mm	20 mm		20 mm	20 mm	24 mm
Suitable for	C-Trafogun AUTOMATIC		Warning! X-gun only						E-Set no. 9 (495645) E-Set no. 12 (495646)
QTY	6 pcs.	4 pcs.	6 pcs.	4 pcs.	6 pcs.	4 pcs.	4 pcs.	4 pcs.	6 pcs.
Item no.	497096	497079	497020	497081	497097	497085	497075	497076	497105



Electrode Cap Set

Item no. 497102

Scope of delivery:
2 x Electrode cap type B (497079)
2 x electrode cap type H (497020)



Electrode caps assortment | Ø 16 mm | C-Trafogun

Item no. 497110

Scope of delivery:
1 x Assortment box
2 x Electrode cap type **A-40**
4 x Electrode cap type **B**
2 x Electrode cap type **E**
2 x Electrode cap type **A-32**
2 x Electrode cap type **H**
2 x Electrode cap type **D**
2 x Electrode cap type **P**





PULLING IN SHEET METAL

BULGING

ESPECIALLY SUITABLE FOR

- HAIL DAMAGE
- SMALL DENTS
- SCRATCHES & STRIPES
- DOUBLE-WALLED SPOTS

HIGH EFFICIENCY

UNRIVALLED IN HANDLING, TIME AND COST SAVINGS

With the Airpuller AP95, dent removal work can be done from the outside in a fraction of the time previously required. Longitudinal scratches, streaks on the side panels or doors can be easily and quickly repaired with the AP95. The well-known hail damage on car roofs can be repaired without any problems.

Airpuller AP95

Airpuller AP95-GT for C-Gun

Item no. 351002

Scope of delivery:
1 x Airpuller AP95
1 x Ground cable

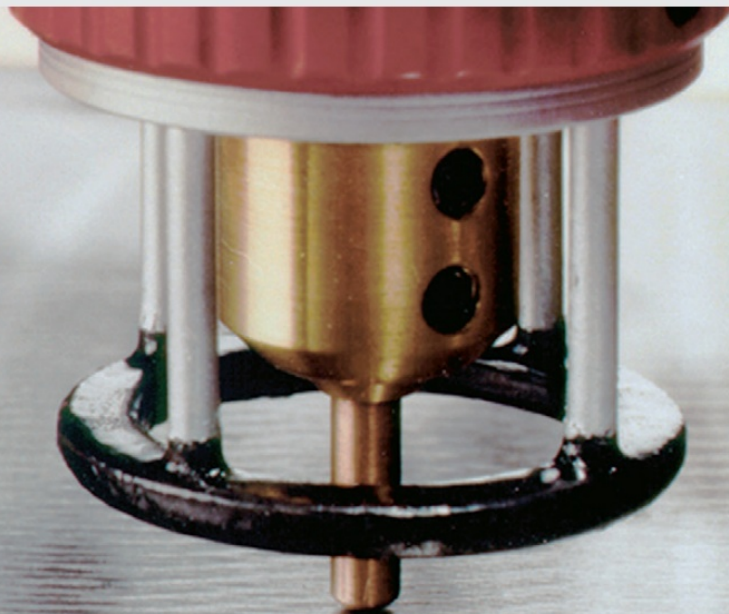

**HIGH ACCESSIBILITY IN
NARROW PLACES**

**PARTICULARLY LIGHT
AND EASY TO HANDLE**



SPOT WELDING GUN PSP - GT

A multifunctional gun for many applications.

By changing the contact pieces, it is possible to attach different bits to the bodywork, matching the type of dent removal method that follows.

Spot welding gun GT - 2.5 m

Item no. 478006

Scope of delivery:

1 x Spot welding gun with SK22

1 x Ground cable with D25

1 x Assortment box (478002)

consists of:

1 x 490007 electrode cap holder incl. cap

1 x 497014 contact piece for wiggle wire

1 x 497015 contact piece for washers

1 x 297009 washers (100 pcs.)

1 x 497016 electrode caps 4 pcs. I type E | \varnothing 13 mm



water-cooled

Spot welding gun GT - 2.5 m

Item no. 478001

GT vicegrip with mounting SK-22 PSP

Item no. 475012



GT vicegrip with mounting D-25 | Ground cable

Item no. 475013



Quick dent pulling hammer | Set

Item no. 478100

Scope of delivery:

- 1 × Quick dent pulling hammer GT (M14)
- 1 × Contact piece for Triangle pulling ring washers (M14)
- 1 × Hook for washers
- 1 × Washers (100 pcs.)
- 5 × Triangle pulling ring washers



Quick dent pulling hammer M14

Item no. 501025

Note:

Suitable for the InvertaSpot GT and the spot welding gun PSP60 (351070)

Scope of delivery:

- 1 × Quick dent pulling hammer GT



Contact piece for Triangle pulling ring washers

Item no.	501031	501033
Thread	M10	M14
QTY /	1 pc. /	1 pc. /



Hook for washers

Item no.	501034
Thread	M14
QTY /	1 pc. /



Contact pieces for spot welding gun PSP

Item no.	497014	497015	497019	497021	497023	497017
Application	Wiggle wire	Washers	T-pins	Studs 2-2.5 + 4 mm	Studs 5 + 6 mm	Upsetting metal
QTY /	1 pc. /	1 pc. /	1 pc. /	1 pc. /	1 pc. /	1 pc. /



Carbon electrode for spot welding gun PSP

Item no. 297107

Diameter: 9.5 mm
Length: 305 mm



Carbon electrode for spot welding gun PSP

Item no. 497026

Diameter: 12 mm
Length: 150 mm



Electrode for spot welding gun PSP

Item no. 297106

Diameter: 12 mm
Length: 98.5 mm



Consumables

Item no.	297013	297009	497028	497025
Item	Triangle pulling ring washers	Washers DIN 125	Washers copper-plated	Weld-on nut M8 copper-plated
VPE	15 pcs.	100 pcs.	100 pcs.	25 pcs.



Weld-on studs | coarse thread

Item no.	297055	297052	297053	297054
Dimensions	5.0 × 9.0 mm	5.0 × 14.2 mm	5.0 × 18 mm	5.0 × 25 mm
Material	Steel 4.8 copper-plated	Steel 4.8 copper-plated	Steel 4.8 copper-plated	Steel 4.8 copper-plated
VPE	15 pcs.	50 pcs.	100 pcs.	25 pcs.



Weld-on pins

Item no.	297031	297032	297033
Item	T-pins 3 × 3.2 mm	T-pins „VV“ 3 × 4.5 mm	T-pins 5 × 10 mm
VPE	100 pcs.	100 pcs.	50 pcs.



Weld-on studs | metric thread

Item no.	497027	297061	297062
Dimensions	M4 × 15 mm	M6 × 12 mm	M6 × 20 mm
Material	Steel 4.8 copper-plated	Steel 4.8 copper-plated	Steel 4.8 copper-plated
VPE	50 pcs.	50 pcs.	50 pcs.



Wiggle wire

Item no.	507030	507031
VPE	10 pcs.	50 pcs.

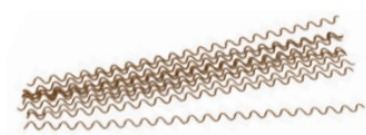

Cover

Item no. 478005

To protect the high-quality spot welding unit from dust, dirt, water.

With Velcro fastener on the side.



Track extension set GT

Item no. 932103

Back-friendly work, relief of arms and shoulders:

When vehicles stand on a straightening bench, some of them are hard to reach.

The user would like to extend the balancer tube upwards. This means that the C-Gun hangs higher overall.

The Track extension set

- extends the straight balancer tube
- widens the wheelbase of the spot-welding unit
- effectively prevents the system from tipping sideways
- provides safety and protection

Scope of delivery:

1 x Balancer tube 630 mm

1 x Insulating webbing 650 mm

2 x Plate left + right

1 x Screw set | 32 pieces



Anticorrosive concentrate WT1000 - 150 ml

Item no. 470008

Suitable for all welding equipment, especially spot welding systems.

Protects sensitive surfaces from corrosion caused by operation with cooling water.

Protects in particular all electronic components, copper cables and copper electrodes from so-called „contact corrosion“.

Mixing ratio 150 ml for 80 litres of coolant.



Item no.	478060	474017	478010	474085
Item	Balancer roller white aluminium	Insulating webbing	Handle extension set for Trafogun 58 mm	Cable bundle holder
VPE	1 pc.	1 pc.	1 pc.	1 pc.



Electrode cap remover

Item no. 498003



Electrode fix | grain 60

Item no. 298298

For cleaning spot welding electrode caps when dirty- Only „clean“ electrode caps guarantee correct spot welding results.



EUROPAX Welding primer - 500 ml

Item no. 817030

Prevents rust and oxidation between sheets for spot welding as well as MIG-MAG.



Electrode copper paste - 75 g

Item no. 497010

- Measurably reduces contact resistances
- Improves the current conduction properties of electrode arms



Welding strips V2A

Item no. 297300

- Stainless steel welding strips
- Used for spot welding of thin aluminium sheets.
- For the outer layer to increase the welding resistance.

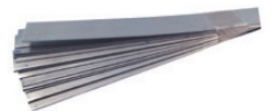







PROFESSIONAL
WELDING TECHNOLOGY

VAS 821 003
Volkswagen
 Approval



Premium
 Shielded gas welding machine



- Energy efficient
- Labor saving
- Updateable
- Advice & Service
- Local support

ASE 821 003 80 000 - 3 x 400 V
 Item no. 932230
 ASE 821 003 80 023 - 3 x 200 V
 Item no. 932231

TABLE OF CONTENTS

Welding machines

InvertaPuls IP 7-2 ACT	60
InvertaPuls IP 6-2 ACT	62
InvertaPuls IP 4-2	64
InvertaPuls IP 4-3	65
IM 240-i	66
IM 240-3	67
WS TIG 200	68

Welding wires	70
Adapter for wire coils	71
Wire wheels & liners	72
Welding torches	73
Current nozzles / gas nozzles	76

Stud welding devices

Alu Pull Kit AK 98	78
Weld-on studs	79
BSP 03	80

Accessories

Flame coating set	81
Aluminium crack testing agent	82
Temperature indicators	82
Welding protection curtains	82
Nozzle cleaning / nozzle protection	83
Ground clamps	83
Welding blankets / spark protection	84
Welding helmets	85

Scope of delivery VAS 821 003

- 1 x welding device 400 V incl. castors
- 1 x 3G torches for steel welding, 3 m
- 1 x kit wire wheels for steel welding 0.6 / 0.8 mm
- 1 x 3G torches for aluminium welding, 3 m
- 1 x kit wire wheels for aluminium welding 1.0 / 1.2 mm
- 1 x set current nozzle (5 x 2 pcs.)
- 1 x storage for 2 x 20 liter gas bottles
- 1 x ground cable
- 1 x user's manual

- Aluminium sheet
- Aluminium profile
- Aluminium casting
- Conventional steel
- Ultra high strength steel
- Magnesium
- CFK

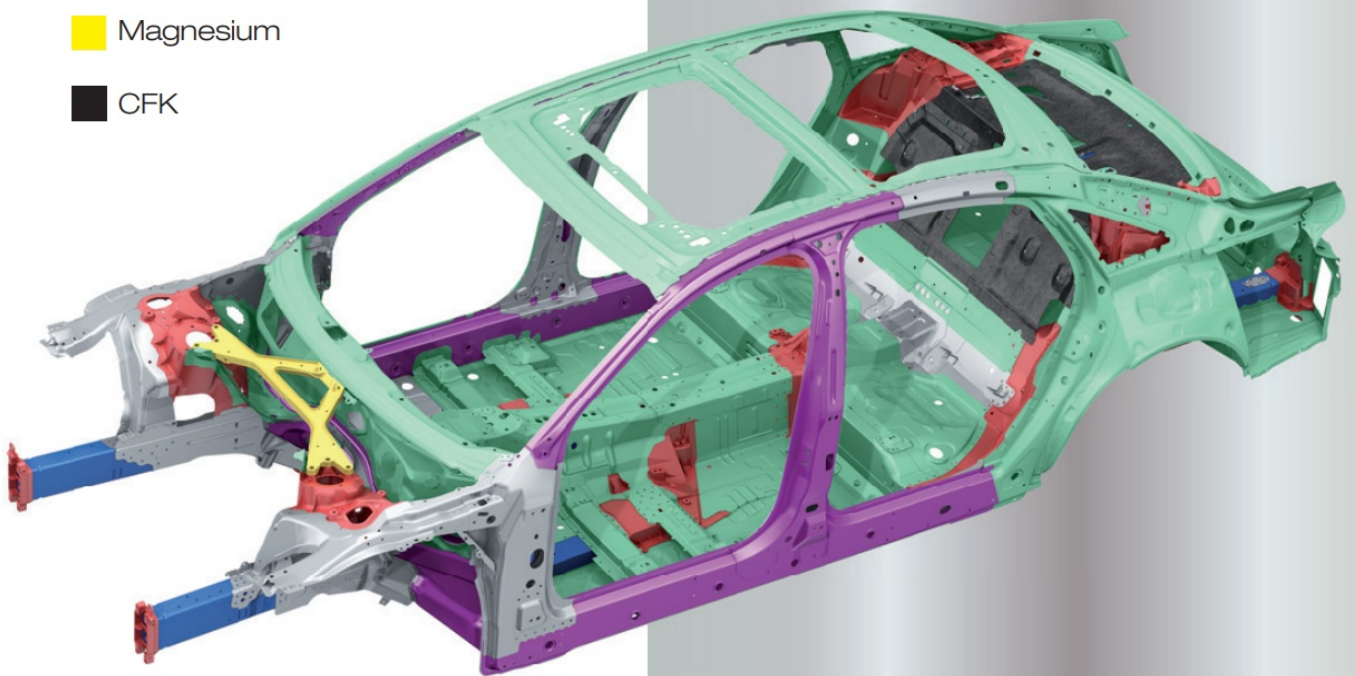

MODERN AND ADVANCED CAR BODY STRUCTURES HAVE THE DEMAND FOR INNOVATIVE AND VERSATILE APPLICABLE WELDING EQUIPMENT.

The 100% synergic welding machines with inverter technology from WS Wieländer+Schill are designed to master all requirements in the field of car body repair with process reliability. A continuous further development of our welding machines guarantees our customers a futureproof investment.

These features are optimally complemented by our services, which are more than above average. A worldwide network of experienced sales partners guarantees first-class consulting and technical knowledge for our customers.

- **MIG brazing - CuSi3, AlBz8, CuAl8**
- **Aluminium welding**
- **Steel welding**
- **Thin sheet steel welding (ACT)**
- **TIG WIG welding**
- **Filler wire welding**
- **Electrode welding**

Description	Configuration		Torch	Power supply	Power range	Pulse	Cycle
IM240-i	STEEL welding	0.6-1.0 mm	1 × MB15, 3 m	230 V / 1-phase	20-200 A		2
IM240-3	STEEL welding MIG brazing	0.6-1.0 mm 0.8-1.0 mm	2 × F200, 3 m	230 V / 1-phase	20-200 A		2
IM240-3 incl. Spool Gun	STEEL welding MIG brazing	0.6-1.0 mm 0.8-1.0 mm	2 × F200, 3 m 1 × Spool Gun	230 V / 1-phase	20-200 A		2
IP4-2 InvertaPuls	STEEL welding MIG brazing	0.6-1.0 mm 0.8-1.0 mm	2 × 3G, 3 m	$\frac{400\text{ V } 3\text{-phase}}{200\text{ V (USA etc.)}}$	10-240 A	•	2/4
IP4-3 InvertaPuls	STEEL welding ALU welding MIG brazing	0.6-1.0 mm 0.8-1.2 mm 0.8-1.0 mm	3 × 3G, 3 m	$\frac{400\text{ V } 3\text{-phase}}{200\text{ V (USA etc.)}}$	10-240 A	•	2/4
IP6-2 InvertaPuls	STEEL welding MIG brazing	0.8 mm 1.0 mm	2 × F200, 3 m	$\frac{400\text{ V } 3\text{-phase}}{200\text{ V (USA etc.)}}$	10-280 A	•	2/4
IP6-2 D InvertaPuls	STEEL welding ALU welding	0.8-1.0 mm 1.0-1.2 mm	2 × 3G, 3 m	$\frac{400\text{ V } 3\text{-phase}}{200\text{ V (USA etc.)}}$	10-280 A	•	2/4
IP7-2 InvertaPuls	STEEL welding MIG brazing	0.6-1.0 mm 0.8-1.0 mm	2 × 3G, 3 m	$\frac{400\text{ V } 3\text{-phase}}{200\text{ V (USA etc.)}}$	10-280 A	•	2/4
IP7-2 InvertaPuls	STEEL welding ALU welding	0.6-1.0 mm 1.0-1.2 mm	2 × 3G, 3 m	$\frac{400\text{ V } 3\text{-phase}}{200\text{ V (USA etc.)}}$	10-280 A	•	2/4

WS TIG 200	TIG welding AC/DC	TIG torch, 4 m	230 V	200 A	TIG only	2/4
------------	---------------------	----------------	-------	-------	----------	-----

Stud welding machines

Description	Welding procedure	Standard torch 3 m	Power supply	Power range	Welding range
Alu Pull Kit AK 98	peak ignition	studs welding gun for ALU	115 V / 230 V (AC)	50-200 A	alu pins Ø 2/3 mm studs M3 - M8
BSP 03	stroke ignition	studs welding gun for STEEL	$\frac{400\text{ V } 3\text{-phase}}{200\text{ V (USA etc.)}}$	800 A	pulling pins Ø 5 / 6 × max.40 mm



IM 240-1



IM 240-3



IM 240-3 + Spool Gun



IP4-2



IP4-3

Thin sheet welding	TIG WIG DC V2A	Drive	Wire rollers	Wire coil Ø	Gas bottle holder	Gas type	Updateable	Item no.	ref.
	•	2 drives	4 guidance	1 x K300 < 15 kg	1 x 20 liter	M21**	•	341290	page 64
	•	2 drives	4 guidance	2 x D200 2 & 5 kg	2 x 20 liter (50 l optional)	Argon 4.6 M21	•	341292	page 65
	•	2 drives	4 guidance	2 x D200 2 & 5 kg	2 x 20 liter (50 l optional)	Argon 4.6 M21**	•	341293	page 65
•*	•	2 drives	4 guidance	2 x D200 2 & 5 kg	2 x 20 liter (50 l optional)	Argon 4.6 M21**	•	<u>341295</u> 341296	page 62
•*	•	2 drives	4 guidance	3 x D200 2 & 5 kg	2 x 20 liter (50 l optional)	Argon 4.6 M21**	•	<u>341298</u> 341299	page 61
•*	•	4 drives	4 guidance	2 x D200 2 & 5 kg	1 x 20 liter (50 l optional)	Argon 4.6 M21**	•	<u>331006</u> 332006	page 60
•*	•	4 drives	4 guidance	2 x D200 2 & 5 kg	2 x 20 liter (50 l optional)	Argon 4.6 M21**	•	<u>331007</u> 332007	page 58
•*	•	4 drives	4 guidance	2 x D200 2 & 5 kg	2 x 20 liter (50 l optional)	Argon 4.6 M21**	•	<u>331026</u> 332026	page 59
•*	•	4 drives	4 guidance	2 x D200 2 & 5 kg	2 x 20 liter (50 l optional)	Argon 4.6 M21**	•	<u>331027</u> 332027	page 66

*ACT = Automotive Cold Transfer I welding mode for thin sheets

**mixed gas M21C18, 80/20, 82/18

	MMA / TIG WIG				1 x 5 liter	14.8 kg (without torches)		331061	page 67
--	---------------	--	--	--	-------------	---------------------------	--	--------	---------

Welding sequence	Welding time	Material	Certification	Weight	Item no.	ref.
up to 20 studs/min. (depending on the diameter)	1-3 ms	aluminium, steel stainless steel, brass metal	UL	11 kg incl. gun	361000	page 76
up to 3 pins/min. (with Ø 6 mm)	1-199 ms (adjustable)	steel and heat resistance steel	UL	32 kg	341001	page 78



InvertaPuls IP 7-2 ACT	Power supply	Welding power
Item no. 331026 steel / brazing kit	3 × 400 V	10-280 A
Item no. 332026 steel / brazing kit	3 × 200 V	10-280 A

High performance welder for steel and brazing

This welding machine with inverter technology has a very simple, self-explanatory, intuitive operation due to the 2-button handling. The digital synergy control (automatic adjustment) regulates the welding parameters optimally. High-end 2 × 4-roller drive for precise wire feed with extra large 37 mm wire rollers for a large welding wire drive support surface. Equipped with a robust industry-compliant, powder-coated sheet steel housing, an ergonomic torch removal and a narrow housing construction with two swivel castors ensure efficient use in any body shop.



Top features

- welding programs for MIG brazing (CuSi3, AlBz8, CuAl8), steel/stainless steel, TIG (WIG), FLUX-cored arc and electrode welding
- special mode for thin sheet steel - ACT technology*
- pulse- and double pulse welding / 2-cycle and 4-cycle mode
- two torches welding machine
- automatic recognition of welding torch
- automatic „Hold-function“ of welding parameters
- 25 memories for individual welding parameters
- USB interface for software update
- very good gap-bridging (gap-filling)
- less material distortion due to lower heat input effects less rework
- high welding velocity

picture shows optional accessories

Scope of delivery:

- 1 × device IP 7-2 incl. castors
- 1 × kit wire drives for steel 0.6/0.8 mm
- 1 × kit wire drives for steel 0.8/ 1.0 mm
- 1 × 3G torch steel, 3 m
- 1 × 3G torch MIG brazing, 3 m
- 1 × ground cable
- 1 × starter set current nozzle
- 1 × user's manual

Info

- *ACT = Automotive Cold Transfer welding mode for thin sheet metal
- ** WG = wire guidance

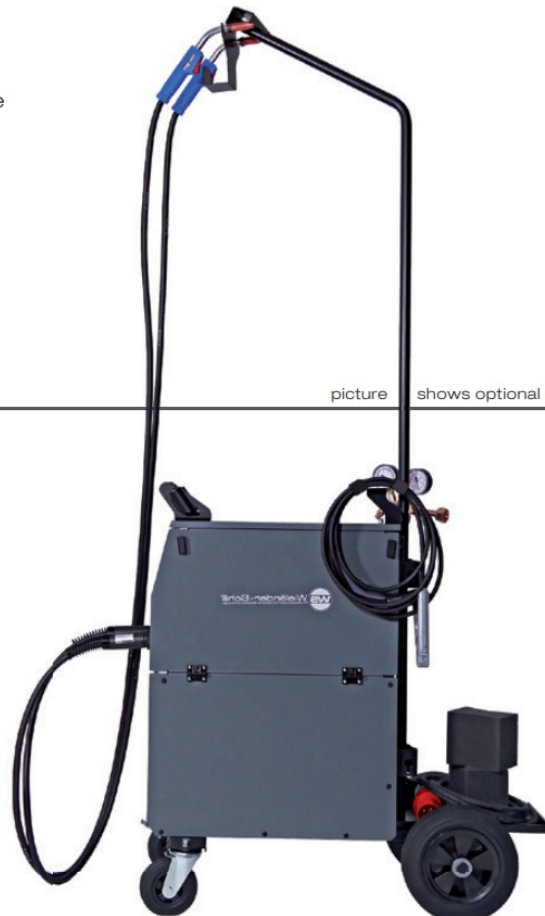

InvertaPuls IP 7-2 ACT	Power supply	Welding power
Item no. 331027 steel / ALU Kit	3 × 400 V	10-280 A
Item no. 332027 steel / ALU Kit	3 × 200 V	10-280 A

High Performance welder for steel and aluminium

Function and technical equipment corresponds to the description item no. 331026 /332026 on page 58.



- Scope of delivery:
- 1 × device IP 7-2 incl. castors
 - 1 × kit wire drives for steel 0.6/0.8 mm
 - 1 × kit wire drives for steel 0.8/ 1.0 mm
 - 1 × kit wire drives for ALU 1.0/1.2 mm
 - 1 × 3G torch steel, 3 m
 - 1 × 3G torch ALU, 3 m
 - 1 × ground cable
 - 1 × starter set current nozzle
 - 1 × user's manual



Accessories for InvertaPuls devices

Item no.	337204	337236	
Description	hanger for 3 torches	wheel space front traverse 50 liter gas bottles	
QTY /	1 pc. /	1 pc. /	



item supplied without torches

InvertaPuls IP 6-2 ACT	Power supply	Welding power
Item no. 331007 steel / ALU kit	3 × 400 V	10-280 A
Item no. 332007 steel / ALU kit	3 × 200 V	10-280 A

Shielded Gas Welding Machine with inverter technology

for MIG brazing aluminium, steel, WIG and thin sheet steel welding. Two 3G welding torches and two welding wire holders in one machine. Outstanding steel thin sheet welding (ACT*). The simple adjustment of the sheet thickness makes the IP 6-2 very user-friendly. A welding machine perfectly adapted for car body repairs.

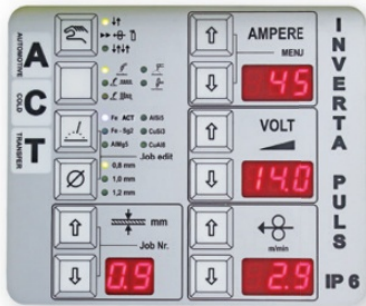

tested and approved by

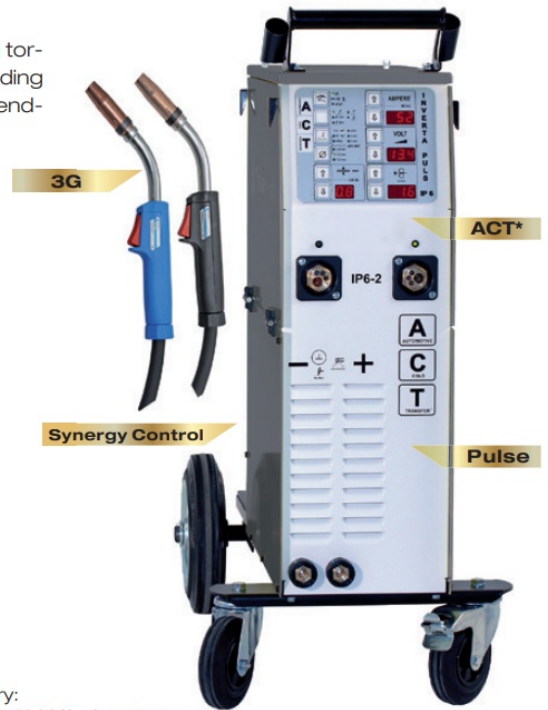

Top features

- high end 4 wheels wire drive
- two torches welding machine
- automatic recognition of welding torch
- automatic „Hold-function“ of welding parameters
- 25 memories for individual welding parameters
- USB interface for software update
- very good gap-bridging (gap-filling)
- less material distortion due to lower heat input effects less rework
- high welding velocity

Scope of delivery:

- 1 × IP 6-2 device 400 V incl. castors
- 1 × 3G torch for steel welding, 3 m
- 1 × 3G torch for aluminium welding, 3 m
- 2 × kits wire drives for steel 0.8/1.0 mm
- 1 × kit wire drives for ALU 1.0/1.2 mm
- 1 × ground cable
- 1 × user's manual

Accessories for IP 6 devices

Item no.	337173	337184	311045
Description	Handle for torch holder (2 ×)	Cable holder for power cable, ground cable etc.	Sheet adapter for second gas bottle fitting for IP 6-2
QTY /	1 pc. /	1 pc. /	1 pc. /

item supplied without torches



InvertaPuls IP 6-2 ACT	Power supply	Welding power
Item no. 331006 steel / brazing kit	3 × 400 V	10-280 A
Item no. 332006 steel / barzing kit	3 × 200 V	10-280 A

Shielded Gas Welding Machine - MIG-MAG version

Function and technical equipment correspond to the description Item no. 331007 / 332007 on page 60.

Info

*ACT = Automotive Cold Transfer welding mode for thin sheet metal

Scope of delivery:

- 1 × device IP 6-2 400 V incl. castors
- 1 × steel torch F200 with steel conductor 3 m, Ø 0.8 mm
- 1 × MIG torch F200 with plastic conductor 3 m, Ø 1.0 mm
- 2 × kits wire guidance for steel 0.8/1.0 mm
- 1 × ground cable with clamp, 3 m
- 1 × manometer
- 1 × T-valve
- 1 × user's manual

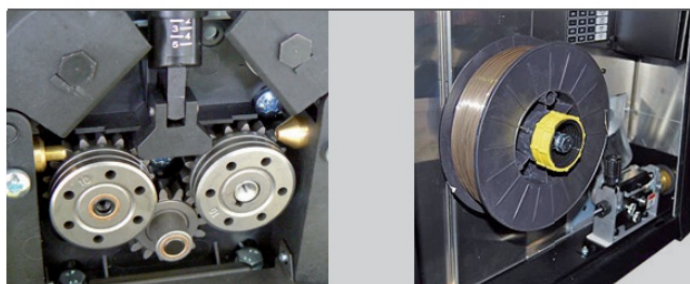

Accessories for welding machines

Item no.	561030	311020	338017
Description	Nipper pliers, weight 790 g	Welding protection spray Trennfix silicon free , 400 ml	Cover hood fitting for InvertaPuls devices
QTY /	1 pc. /	1 pc. /	1 pc. /

Designed for disassembly work in car body repair.



Cutting edges are additionally hardened. Blade hardness approx. 59 HRC. Made of forged special tool steel, oil-hardened. The pliers are black atramentised with polished head.

Release agent and lubricant, very economical. Prevents rapid clogging of the welding torch by welding spatter on gas and current nozzles.



Item no.	311044	311042
Description	Double branch valve 1/4" for manometer CO2 / Argon	Manometer / Pressure reducer CO2 / Argon / mixed gas
QTY /	1 pc. /	1 pc. /



Measuring range: 0 - 30 L/M
 Hose connection: G 1/4 RH
 Bottle connection: W21.80 × 1/14 „RH
 stepless adjustment with high accuracy



InvertaPuls IP 4-2	Power supply	Welding power
Item no. 341295 steel / brazing kit	3 x 400 V	10-240 A
Item no. 341296 steel / brazing kit	3 x 200 V	10-240 A

MIG-MAG Inverter Welding machine

with 2 x welding torches for steel welding and MIG brazing. Also for aluminium - TIG - thin sheet welding* - only the sheet thickness has to be adjusted - very user-friendly. With connection for an additional Spool Gun hose package.



- Scope of delivery:
- 1 x IP4-2 device 400 V cpl.
 - 1 x 3G torch for steel welding, 3 m
 - 1 x kit wire liner for steel, 0.6/0.8 mm
 - 1 x 3G torch for MIG brazing, 3 m
 - 1 x kit wire liner for steel, 0.8 /1.0 mm
 - 1 x ground cable
 - 1 x starter set current nozzle
 - 1 x gas bottle attachment
 - 1 x user's manual



Top features

- automatic recognition of welding torch
- automatic „Hold-function“ of welding parameters
- memories for individual welding parameters
- interface for software update
- less heat input
- less material distortion
- less rework
- high welding velocity
- connection for Spool Gun torch

(accessories on page 64)

Info

*ACT = Automotive Cold Transfer welding mode for thin sheet metal

Accessories

Item no.	308111	337142	337221
Description	3G torch ALU , 3 m Ø 1.0 mm nozzle, conductor red	plastic connector ALU red, length 3.5 m	wire feeding rolls ALU Ø 1.0 / 1.2 mm
QTY /	1 pc. /	1 pc. /	1 pc. /



InvertaPuls IP 4-3	Power supply	Welding power
Item no. 341298 steel / brazing / ALU kit	3 x 400 V	10-240 A
Item no. 341299 steel / brazing / ALU kit	3 x 200 V	10-280 A

MIG-MAG / ALU Inverter welding machine

The ALL-ROUNDER for the car body professional for steel welding, MIG brazing and aluminium welding. With connections for 3 hose packages. A welding machine perfectly adapted to vehicle repair.

NEW



welding programs for:

- MIG brazing
- Aluminium welding
- Steel/stainless steel
- TIG (WIG)
- FLUX-cored arc and electrode welding



Top features

- welding power 240 A
- pulse- and double pulse welding / 2-cycle and 4-cycle mode
- automatic recognition of welding torch
- automatic „Hold-function“ of welding parameters
- wire feeding system with 4 wheel drive
- memories for individual welding parameters
- less heat input
- very good gap-bridging (gap-filling)



Info

for the use of 2 x 50 litre gas bottles a wheel spacer front traverse required.
 Item no. 337236 on page 65

item supplied without gas bottles

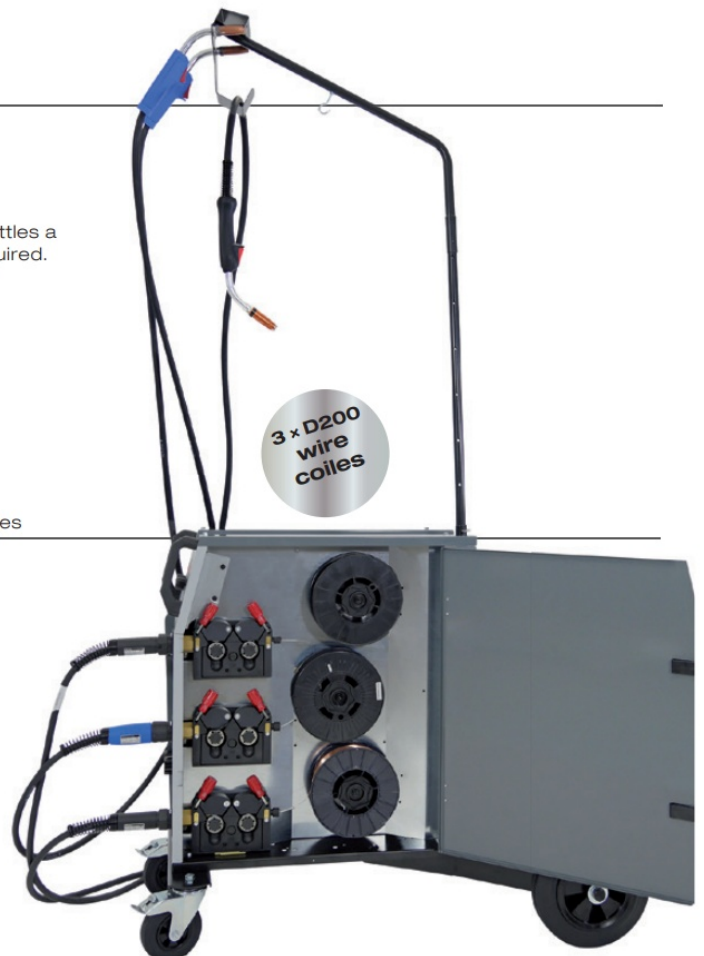

Scope of delivery:

- 1 x InvertaPuls device IP4-3 cpl.
- 1 x kit wire liner for steel welding 0.6/0.8 mm
- 1 x kit wire liner for MIG brazing 0.8/1.0 mm
- 1 x kit wire liner for aluminium 1.0/1.2 mm
- 1 x 3G torch for steel welding 3 m
- 1 x 3G torch for MIG brazing, 3 m
- 1 x 3G torch for aluminium welding, 3 m
- 1 x ground cable
- 1 x starter set with current nozzels
- 1 x user's manual

IM 240-i welding machine

Power supply

Welding power

Item no. 341290 **steel kit**

230 V

20-200 A

Standard welding machine

A welding system that is very easy to adjust, absolutely uncomplicated, very robust design - withstands even hard treatment.



Scope of delivery:

- 1 x IM 240-i device incl. castors
- 1 x gas bottle attachment
- 1 x Force 200 torch for steel, 3 m with wire guidance spiral
- 1 x kit wire guidance for steel 0.8/0.6 mm
- 1 x ground cable 4 m
- 1 x user's manual

entry level model

Force 200

Synergy Control



Top features

- MIG MAG brazing / welding
- 4 wheel drive with fine adjustment / wire velocity 1.5-15 m/min.
- fixture for K300 coils (17 kg max.)
- automatic „Hold-function“ for welding power and welding voltage
- dynamic adjustment - end pulse to release the ball at the end of the wire
- good welding performance in the thin sheet metal range, e.g. with 0.6 mm sheet steel

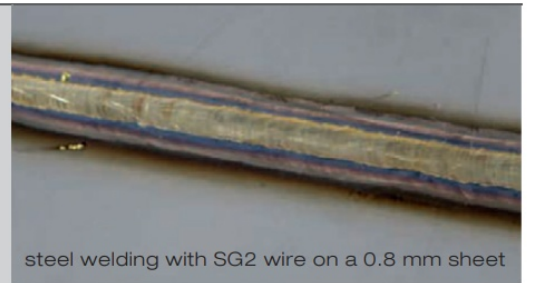

steel welding with SG2 wire on a 0.8 mm sheet

Accessories welding machines

Item no.	311043	374415	304053
Description	magnetic holder for torches	ground clamp without cable	ground clamp with cable 5 m
QTY /	1 pc. /	1 pc. /	1 pc. /



IM 240-3 welding machine	Power supply	Welding power
Item no. 341292 steel / brazing kit	230 V	20-200 A

The **ALL-ROUNDER** for the car body professional - steel welding, aluminium welding and MIG soldering. 2-torch MIG/MAG inverter welding system - fully synergic control.



- Scope of delivery:
- 1 x IM 240-3 device, 230 V
 - 1 x Force 200 torch 3 m for steel welding wire spiral and 0.8 mm current nozzle
 - 1 x Force 200 torch 3 m for MIG brazing, teflon core and 0.8 mm current nozzle
 - 1 x kits wire guidance for steel welding Ø 0.8 mm
 - 1 x kits wire guidance for MIG brazing Ø 1.0 mm
 - 1 x ground clamp with cable 4 m
 - 1 x gas bottle attachment for 2 x 20 liter
 - 1 x user's manual



Top features

- no retooling necessary thanks to the 3-torches system and wide holder for 2 gas bottles - 20 l or 50 l*
- connector for Spool Gun torch*
- 2 button control guarantees intuitive and simple operation
- with full synergy control
- 200 A welding power / 230 V inverter technology for optimum welding processes
- 2 x mounting fixtures for D200 wire coils
- welding programs for steel with wire dia. 0.6 mm to 1.0 mm and CuSi 0.8 mm to 1.0 mm also AISi and AlMg for 1.0 mm diameter

*equipment version with optional accessories



IM 240-3
incl. **Spool GUN**
torch cpl.
Item no. 341293

Accessories 240-3 welding machine

Item no.	337204	308115	337236
Description	hanger, height 1.9 m for 3 torches	spool GUN torch cpl.	wheel spacer front traverse for 50 liter gas bottles
QTY /	1 set	1 pc. /	1 pc. /



WS TIG 200 welding machine	Power supply	Weight	Welding power
Item no. 331051	230 V	14,8 kg	200 A

Inverter TIG welder

Mobile and powerful. High pulse and low pulse welding, and MIX-Tig. Synergy welding with the easy-to-use front input system.

Designed as a self-explanatory and intuitive welding device

Top features

- dynamic pulsed arc for more productivity, faster welding and better arc control
- AC Wave/current modulation - defined weld seams and modulated weld seam geometry
- MixTIG - especially suitable for aluminum welding
- Active Boost - protects against the triggering of the mains fuse
- Hyper Active Arc - the new active arc for constant heat input
- High-frequency impulse welding with dynamic control of the arc, reduces the heat input

Outstanding weight vs power

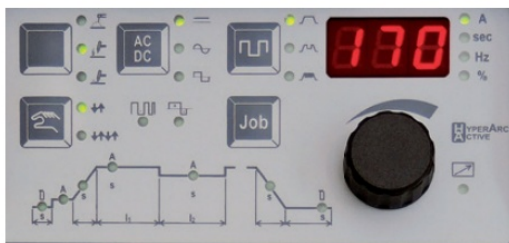

Scope of delivery:

- 1 x TIG 200 A device
- 1 x TIG torch SR26, Ø 2.4 mm, 4 m
- 1 x ground cable 4 m with clamp
- 1 x pressure reducer Arg/Co2
- 1 x user's manual



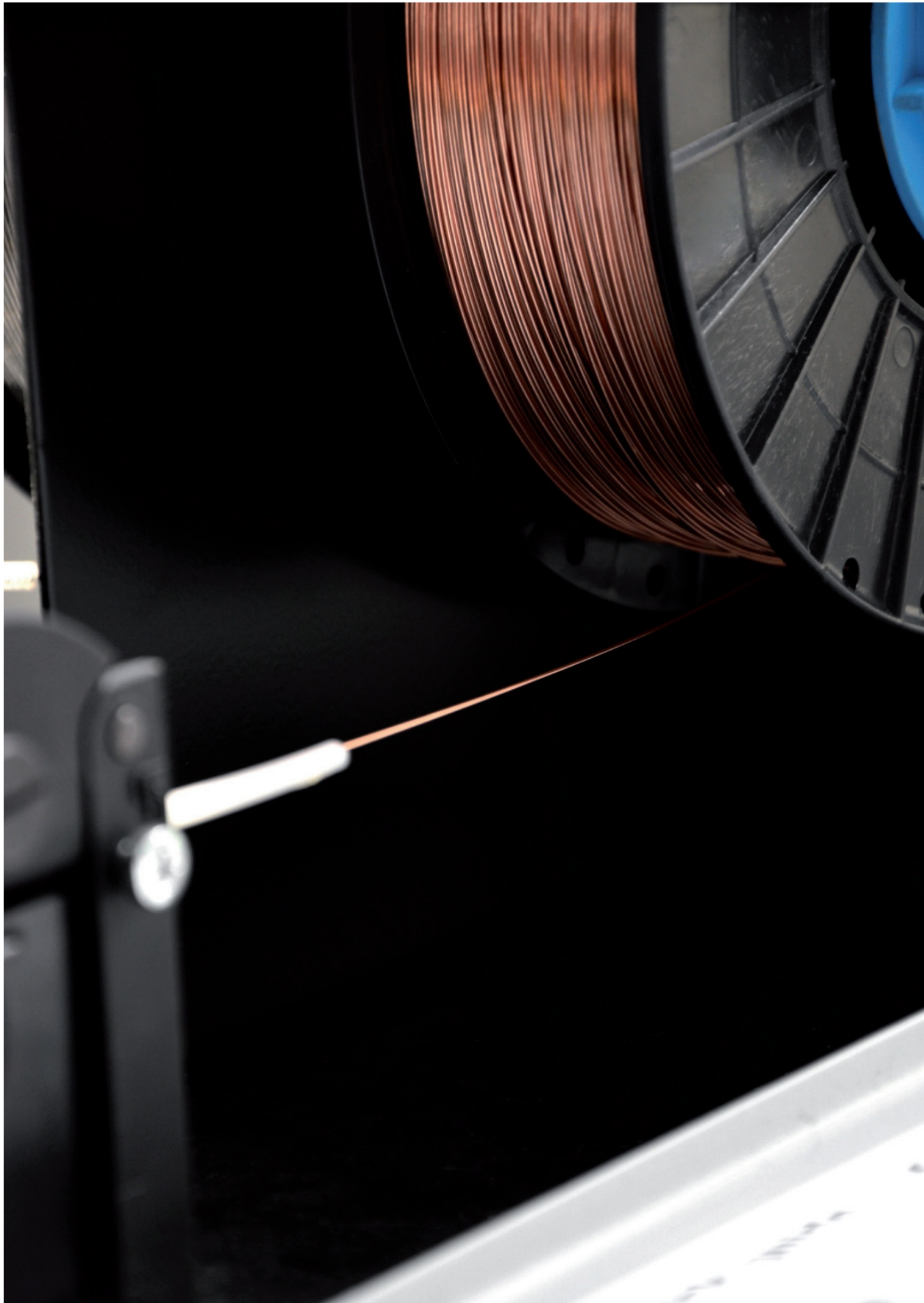

Welding wire for welding machines IP4 | IP6 | IP7 | IM 240-3



D200

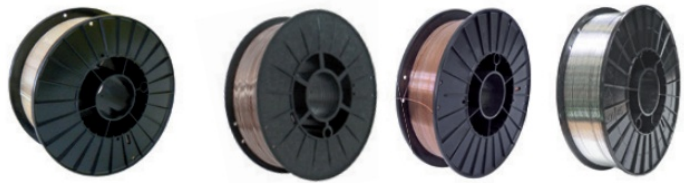

Item no.	311074	311075	311082	311093	311076	311077	311078	311079
Description	SG2 Tivb	SG2 Tivb	SG2	SG2	AlMg5	AlMg5	AlSi5	AlSi5
Diameter	0.8 mm	1.0 mm	0.8 mm	0.6 mm	1.0 mm	1.2 mm	1.0 mm	1.2 mm
Coil type	D200	D200	D200	D200	D200	D200	D200	D200
Weight QTY	5.0 kg	5.0 kg	5.0 kg	5.0 kg	2.0 kg	2.0 kg	2.0 kg	2.0 kg

Item no.	311080	311081	311070	311071	311072	311073	311036	311087
Description	AlSi12	AlSi12	CuSi3	CuSi3	AlBz8/ CuAl8	AlBz8/ CuAl8	NimoCro	Union X96
Diameter	1.0 mm	1.2 mm	0.8 mm	1.0 mm	1.2 mm	1.0 mm	0.8 mm	0.8 mm
Coil type	D200	D200	D200	D200	D200	D200	D200	D200
Weight QTY	2.0 kg	2.0 kg	5.0 kg	5.0 kg	5.0 kg	5.0 kg	5.0 kg	5.0 kg



D100



Item no.	311090	311091	311092	821454	311089	821455		
Description	AlSi12	AlSi5	AlMg5	AlSi12	AlSi5	AlMg5		
Diameter	1.0 mm	1.0 mm	1.0 mm	0.8 mm	0.8 mm	0.8 mm		
Coil type	D100	D100	D100	D100	D100	D100		
Weight QTY	0.5 kg	0.5 kg	0.5 kg	0.5 kg	0.5 kg	0.5 kg		

Wire type	Application	Recommended inert gas ISO 14175, EN 439, DIN 32526	OEM used*
CuSi3	MIG brazing	Argon 4.6	Ford MB Honda JLR Opel PSA
AlBz8/CuAl8	MIG brazing	Argon 4.6	MB PSA
NimoCro	low-alloy & high-strength steel	mixed gas Argon / Co ₂ M21C(R)18, 80/20, 82/18	
Union X96	MAG welding high & highest strength steel	mixed gas Argon / Co ₂ M21C(R)18, 80/20, 82/18	Honda Tesla

Approval

Welding wire K300 for IM240-i

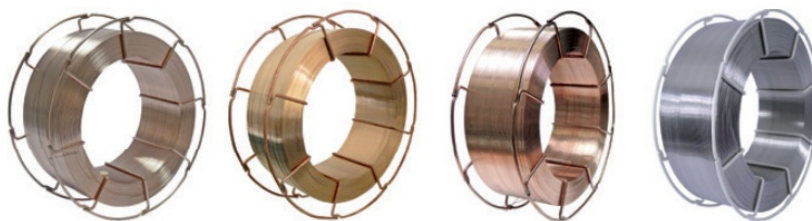
K300

Item no.	311001	311002	311015	311024	311025	311016	311022	311023
Description	SG2	SG2Tivb	AlMg5	AlMg5	AlSi5	AlSi5	AlSi12	AlSi12
Diameter	0.8 mm	0.8 mm	1.0 mm	1.2 mm	1.0 mm	1.2 mm	1.0 mm	1.2 mm
Coil type	K300	K300	K300	K300	K300	K300	K300	K300
Weight QTY	15.0 kg	15.0 kg	7.0 kg	7.0 kg	7.0 kg	7.5 kg	7.0 kg	7.0 kg

Item no.	311018	311019	311027	311004	311028		311010	311007
Description	CuSi3	CuSi3	AlBz8/ CuAl8	AlBz8/ CuAl8	AlBz8/ CuAl8		NimoCro	Union X96
Diameter	0.8 mm	1.0 mm	1.2 mm	1.0 mm	1.2 mm		0.8 mm	0.8 mm
Coil type	K300	K300	K300	K300	K300		K300	K300
Weight QTY	15.0 kg	15.0 kg	5.0 kg	15.0 kg	15.0 kg		15.0 kg	15.0 kg

Accessories for welding wire

Item no.	307004	307003	307002
Description	adapter for wire coil D200	adapter for basket wire coil 2 parts	adapter for basket wire coil 1 part
QTY /	1 pc. /	1 pc. /	1 pc. /



Scope of delivery
 1 x adapter for wire coil
 1 x spacer ring | wide 15 mm | Ø 55 mm
 2 x spacer rings | wide 10 mm | Ø 55 mm

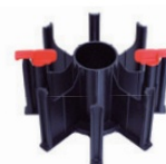

Info

*we offer welding wire that corresponds to the OEM configuration in material and quality

Wire	Application	Recommended inert gas ISO 14175, EN 439, DIN 32526	OEM used*
SG2	steel	mixed gas Argon / Co ₂ M21C(R)18, 80/20, 82/18	VW JLR
SG2 Tivb bronzed	steel galvanized	mixed gas Argon / Co ₂ M21C(R)18, 80/20, 82/18	VW
AlMg5	aluminium	Argon 4.6	Honda
AlSi5	aluminium	Argon 4.6	BMW / MB / Honda / JLR
AlSi12	aluminium	Argon 4.6	Audi / MB / Honda / JLR

Wire wheels sets

Item no.	337219	337220	337221	337215	337216	337217
Welding device	IP4 IP6 IP7 IM 240	IP4 IP6 IP7 IM 240	IP4 IP6 IP7 IM 240	IM 240-i (V1)	IM 240-i (V1)	IM 240-i (V1)
Diameter	0.6 + 0.8 mm	0.8 + 1.0 mm	1.0 + 1.2 mm	0.6 + 0.8 mm	0.8 + 1.0 mm	0.8 + 1.0 mm
Type	Steel MIG	Steel MIG	ALU	Steel MIG	Steel MIG	ALU
QTY	2 pcs.	2 pcs.	2 pcs.	1 pc.	1 pc.	1 pc.

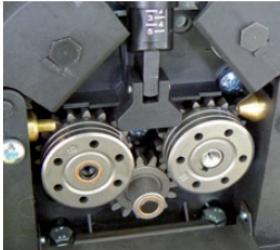

Wire liner and conductor

Item no.	337106	337107	337108
Description	wire liner conductor blue 4 m wire sizes Ø 0.8 + 1.0 mm Steel	wire liner conductor blue 3 m wire sizes Ø 1.0 + 1.2 mm Steel	teflon wire liner red Ø 1.0 + 1.2 mm incl. copper neck liner 220 mm ALU
QTY /	1 pc. /	1 pc. /	1 pc. /



Item no.	337109	337147
Description	teflon wire liner black Ø 0.8 + 1.0 mm incl. copper neck liner 220 mm MIG	polyimide plastic liner incl. copper neck 3.5 m wire sizes Ø 0.8 + 1.0 mm MIG
QTY /	1 pc. /	1 pc. /



Service Hotline
+49 (0)7464 9898 125

Info
* CL = conductor liner
PL = plastic liner
TWL = teflon wire liner

Item no.	337139	337142	337015
Description	teflon liner blue 3.5 m wire sizes Ø 0.8 + 1.0 mm ALU	teflon liner red 3.5 m wire sizes Ø 1.0 + 1.2 mm ALU	teflon wire liner red 4.5 m wire sizes Ø 1.0 + 1.2 mm ALU
QTY /	1 pc. /	1 pc. /	1 pc. /



Item no. 337143
O-ring for teflon liners
QTY 1 pc.



Item no. 337110
copper neck liner 220 mm for
plastic wire liner red and black
QTY 1 pc.

3G torches for InvertaPuls IP4 | IP6 | IP7 | TWIN

High-End manual welding torches with mini handle offer a combination of handiness and outstanding accessibility, even under difficult working conditions.

Top features

- cooling type gas cooled
- load capacity 180 A mixed gas (60%)
- wire diameter 0.8-1.2 mm
- easy to service due to exchangeable nozzle holder



Item no.	308110	308111	308116
Description	3G torch Steel 3 m Ø 0.8 mm nozzle blue CL liner	3G torch ALU 3 m Ø 1.0 mm nozzle red PL liner	3G torch MIG 3 m Ø 0.8 + 1.0 mm nozzle teflon liner
QTY /	1 pc./	1 pc./	1 pc./



Spare parts for 3G torches

307010	307011	307015	307018	307012	307014	307016	307013
gas nozzle conical	gas nozzle cylindrical	torch neck	torch neck mini	splash protec. for gas nozzle	clamping piece for gas distrib.	isolation sleeve	gas distributor
1 pc.	1 pc.	1 pc.	1 pc.	1 pc.	1 pc.	1 pc.	1 pc.



Force 200 torch for IM 240-i | IM 240-3

Item no.	308101	308102	308103
Description	Force 200 torch ALU 3 m Ø 1.0 mm nozzle red PL liner	Force 200 torch MIG 3 m Ø 0.8 mm nozzle black teflon liner	Force 200 torch Steel 3 m Ø 0.8 mm nozzle blue CL liner
QTY /	1 pc./	1 pc./	1 pc./



Spare parts for Force 155 | 200 torches

Item no.	307008	307009	307070	307040	307071	307072
Description	insulation sleeve for torch neck	nozzle holder	torch neck	gas nozzle conical	hexagon nut short M10 x 1 x 5 mm	hexagon nut long M10 x 1 x 26 mm
QTY /	1 pc. /	1 pc. /	1 pc. /	1 pc. /	1 pc. /	1 pc. /



MB24 | TIG | Spool Gun torches

Item no.	308105	308107	308109
Description	torch MB24 Steel 3 m nozzle Ø 0.8 mm	torch MB24 ALU 3 m nozzle Ø 1.2 mm	torch MB24 MIG 3 m with PA liner* nozzle Ø 1.0 mm
QTY /	1 pc. /	1 pc. /	1 pc. /



* polyamide

Item no.		308115	332222
Description		torch Spool Gun ALU length 3 m	torch TIG SR 17 hand gas valve
QTY /		1 pc. /	1 pc. /



spare parts for MB15/MB24 torches

Item no.	307025	307034	307030	307031	307032	307024
Description	gas diffuser Ø 17 mm / MB24	retaining spring MB14 / MB15	gas distr. holder MB24	gas distr. holder MB15	gas distr. holder MB25	protective sleeve MB15
QTY	1 pc.	1 pc.	1 pc.	1 pc.	1 pc.	1 pc.



Item no.	307021	307022	307023
Description	swan neck standard for MB15	swan neck flexible MB15	swan neck standard for MB24
QTY	1 pc.	1 pc.	1 pc.



Gas tester

This gas flow tester is used to precisely measure the flow rate of **Argon/CO2**. The gas flow tester is very accurate and gives very accurate results.

Item no. 311048

Service Hotline
+49 (0)7464 9898 125

Torches **SB | SBT 154G* | SBT 307G***

Manual welding torch for optimum welding results for step-switched MIG-MAG units.

Top features

- optimal torch cooling by double gas guiding system (*only SBT 307G*)
- insulated torch body construction (*SBT 307G only*)
- kink protection on the hose package
- screwed, impact-resistant grip plates
- easy to service due to exchangeable nozzle holder
- screwed gas nozzles
- encapsulated micro switch in the torch switch



Info

*SBT 154 / 307G torch for InvertPuls IP8 and IP10 - note this devices no longer available

Item no.	332216	332217	332218	332219		332201	332211
Description	SB 157G	SBT 157G	SBT 157G	SBT 157G		SBT 307G	SBT 307G
Length	4 m	3 m	3 m	3 m		3 m	3 m
Diameter	0.8 mm	1.0 mm	0.8 mm	1.0 mm		0.8 mm	1.0 + 1.2 mm
Type	Steel	Steel	Stahl	ALU		Steel	ALU
Power	180 A, 60%	180 A, 60%	180 A, 60%	180 A, 60%		300 A, 60%	300 A, 60%
QTY	1 pice	1 piece	1 piece	1 piece		1 set	1 set
Item supplied incl.						wire wheels 25/4 2 × wire nozzles 2 × nozzles	wire wheels 26 2 × wire nozzles 2 × nozzles

spare parts for torch **SB / SBT 154 G**

spare parts for torch **SBT 307 G**

Item no.	337100	337103	337102	337104
Description	torch body SB/SBT 154 G	gas distributor holder SB/SBT 154 G	gas diffuser SBT 307 G	gas distributor holder SBT 307 G
QTY /	1 pc. /	1 pc. /	1 pc. /	1 pc. /





Item no.	337209	337210	337211	337212		337213	337214
Description	DV25/4	DV25/4	DV25/4	DV25/4		DV26	DV26
Diameter	1.0 mm	0.8 mm	1.0 mm	1.2 mm		0.8 + 1.0 mm	1.0 + 1.2 mm
Type	Steel MIG	Steel MIG	ALU	ALU		Steel MIG	ALU
QTY	1 set	1 set	1 set	1 set		2 pcs.	2 pcs.



Current nozzles

								
Item no.	307033	307035	307036	307037	307038		307045	307046
Size	M6 × 25	M6 × 25	M6 × 25	M6 × 28	M6 × 25		M6 × 25	M6 × 25
Diameter	0.6 mm	0.8 mm	1.0 mm	0.8 mm	1.0 mm		1.0 mm	1.2 mm
Type	Steel / MIG	Steel / MIG	Steel / MIG	Steel / MIG	Steel / MIG		ALU	ALU
Material	ECu*	ECu*	ECu*	ECu*	ECu*		ECu*	ECu*
Torch	MB15/24/25 MB26 / 3G Force 155/200	MB15/24/25 MB26 / 3G Force 155/200	MB15/24/25 MB26 / 3G Force 155/200	MB15/24/25 MB26 / 3G Force 155/200	MB15/24/25 MB26 / 3G Force 155/200		MB15/24/25 MB26 / 3G Force 155/200	MB15/24/25 MB26 / 3G Force 155/200
QTY	10 pcs.	10 pcs.	10 pcs.	10 pcs.	10 pcs.		10 pcs.	10 pcs.

								
Item no.	307050	307051		307052	307053	307054		
Size	M6 × 28	M6 × 28		M6 × 28	M6 × 28	M6 × 28		
Diameter	1.0 mm	1.2 mm		0.8 mm	1.0 mm	0.6 mm		
Type	ALU	ALU		Steel / MIG	Steel / MIG	Steel		
Material	ECu*	ECu*		ECu*	ECu*	ECu*		
Torch	MB15/24/25 MB26 / 3G Force 155/200	MB15/24/25 MB26 / 3G Force 155/200		MB15/24/25 MB26 / 3G Force 155/200	MB15/24/25 MB26 / 3G Force 155/200	MB15/24/25 MB26 / 3G Force 155/200		
QTY	10 pcs.	10 pcs.		10 pcs.	10 pcs.	10 pcs.		

								
Item no.	337120	337121	337122			337117	337115	337116
Size	M6 × 25	M6 × 25	M6 × 25			M8 × 27	M8 × 27	M8 × 27
Diameter	0.8 mm	1.0 mm	1.2 mm			1.2 mm	0.8 mm	1.0 mm
Type	Steel / MIG	Steel / MIG	ALU			ALU	Steel / MIG	Steel / MIG
Material								
Torch	SBT 154 G	SBT 154	SBT 154 G			SBT 307 G	SBT 307 G	SBT 307 G
QTY	10 pcs.	10 pcs.	10 pcs.			10 pcs.	10 pcs.	10 pcs.

Info

*E-copper - particularly high conductivity with high corrosion resistance and high temperature coefficients

Gas nozzle



Item no.	307010	307011	307040	307042	307043	307044
Length	63.5 mm	63.5 mm	54 mm	57 mm	63.5 mm	75.5 mm
Ø (inside)	12.5 mm	17 mm	12.5 mm	15 mm	12.5 mm	16 mm
Form / type	conical, pluggable	cylindrical, pluggable	conical, pluggable	conical, pluggable	conical, pluggable	conical, pluggable
Model coating	copper	copper	chrome-plated	chrome-plated	copper	copper
Torch	3G	3G	MB14 MB15 Force 155/200	MB25	MB24	MB26
QTY	1 pc.	1 pc.	1 pc.	1 pc.	1 pc.	1 pc.



Item no.	307047	337125	337126	337132	337130	337131
Length	63 mm (56)	55 mm	74 mm	47 mm / Gr. 5	47 mm /Gr.6	47 mm / Gr.7
Ø (inside)	16 mm	14.5 mm	15 mm	8 mm	9.5 mm	11 mm
Form / type		conical, screwable	conical, screwable	pluggable	pluggable	pluggable
Model coating	chrome-plated	chrome-plated	chrome-plated	ceramics	ceramics	ceramics
Torch	MB14 MB15 Force 155/200	SB/SBT 154G	SB/SBT 307G	TIG SR17 26	TIG SR17 26	TIG SR17 26
QTY	1 pc.	1 pc.	1 pc.	1 pc.	1 pc.	1 pc.

Welding accessories

Item no.	311041	311026	311040
Description	special plier for gas welder with 4 functions	protection paste for gas nozzle 350 ml	cleaner kit 13 pcs. for current nozzle
QTY /	1 pc. /	1 pc. /	1 pc. /



For all welding nozzles. Fast and accurate trimming of the welding wire, time-saving cleaning of the shielding gas nozzle, pulling off the shielding gas nozzle, loosening and tightening the nozzle.

silicon-free



Prevents rapid clogging of the welding torches by welding spatter on gas and current nozzles.



12-piece nozzle cleaning needle kit in the practical, hinged metal box. With approx. 90 mm long needle files from Ø 0.4 to 1.6 mm including 1 flat file for cleaning welding nozzles.

Stud welding machines

Alu Pull Kit AK98	Power supply	Welding sequence / min.	Weight
Item no. 361000	230 V / 115	20 bolt / studs	11 kg

The innovative stud welding technology with automatic gun and 100% microprocessor control revolutionises the dent removal of aluminium sheets in bodywork and vehicle construction. Stud welding with capacitor discharge technology and capacitor discharge ignition, is a cold stud welding process. The aluminium body sheet is protected, no burn marks are left on the back of the body sheet.



tested and approved by

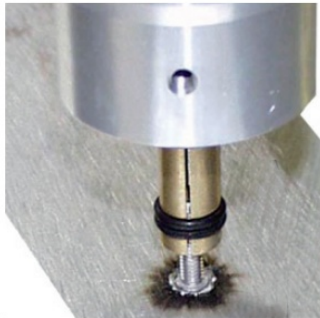

Scope of delivery:
 1 x control unit AK98
 1 x welding gun aluminium incl. welding cable 3 m
 1 x adapter stud welding diam 4 mm
 100 x alu-studs M4 x 15 mm
 2 x earth cable 3 m
 1 x assembling tool
 1 x transport case
 3 x pulling rods
 3 x screw pins
 1 x working instructions

Range of application:

includes small dents, dents, longitudinal scratches and hail damage. The **Alu Pull Kit** is used on modern passenger cars, truck bodies, bus covers, camper vans, mobile homes and in container construction. All dent removal work is carried out from the outside, there is no need for laborious pressing from the inside.

The precise digital display of the charge voltage enables precise adjustment of the performance parameters. Dent removal with the **Alu Pull Kit AK 98** is easy to learn, saves working time and reduces repair costs.

Tech. Data for standard welding application:

aluminium studs Ø 4 mm | welding sequence up to 20 studs/min. | welding process: tip ignition
 welding time: 0.001-0.003 sec. | 66.000 µF

Accessories for Alu Pull Kit AK98

Item no.	368001	368005	368002
Description	stud welding gun for aluminium studs	special attachment type Audi for stud welding gun steel	stud welding gun for steel studs Ø 3-8 mm
QTY /	1 pc. /	1 pc. /	1 pc. /



Accessories for Alu Pull Kit AK98

Item no.	368104	368105	368106
Description	contact piece M4 for welding studs ALU	contact piece M5 for welding studs ALU	contact piece M6 for welding studs ALU
QTY /	1 pc. /	1 pc. /	1 pc. /



Item no.	368060	351060	368020
Description	welding studs gripper for 4 mm studs	Maxilift with 3-finger claws	side cutter 160 mm
QTY /	1 pc. /	1 pc. /	1 pc. /



For pinching off the aluminium studs. With polished head, handles covered with plastic.

Item no.	368043	368040	368050
Description	pull gripper screwable M4	pull gripper screwable M4	pull rod V2A steel length 160 mm
QTY /	3 pcs. /	10 pcs. /	3 pcs. /



Aluminium studs - metric thread | T-thread (self lock)



Item no.	367015	367016	367017	367045	367050	367030	367035	367040
Thread length	M4 x 15 mm	M4 x 15 mm	M4 x 15 mm	M6 x 12 mm	M6 x 16.5 mm	T5 x 10.5 mm	T5 x 15.5 mm	T5 x 25 mm
Material type	AlSi12	AlSi12	AlMg3	AlSi12	AlSi12	AlSi12	AlSi12	AlSi12
QTY	100 pcs.	1000 pcs.	100 pcs.	100 pcs.	100 pcs.	100 pcs.	100 pcs.	100 pcs.



BSP 03	Power supply	Ø pulling bolts	Weight
Item no. 341001	3 × 400V	5 × 16 × 40 mm	32 kg

Special stud welding device e.g. opening of series punch rivet connections. In this process stainless steel studs are welded onto self-pierce rivets.

With mobile workshop trolley incl. gas cylinder holder (max. 5 liters).



tested and recommended by



- Scope of delivery:
- 1 × BSP 03 welding unit
 - 1 × BSP03 gun cpl. with welding cable
 - 2 × earth cable complete with pliers
 - 1 × studholder Ø 6 mm (type V2A-SA)
 - 1 × plug wrench 17-17 for mounting studholder
 - 1 × pulling bolts V2A-SA Ø 6 × 40 mm, QTY 500 pcs.
 - 1 × gas hose
 - 1 × trolley
 - 1 × operation instruction

Top features

- easy operation due to infinitely variable up and down regulation of the charging voltage
- automatic maintenance of constant charging voltage
- high power reserves in marginal cases and for difficult welding tasks
- no negative impact on the system in case of mains voltage fluctuations (-10/-15%)

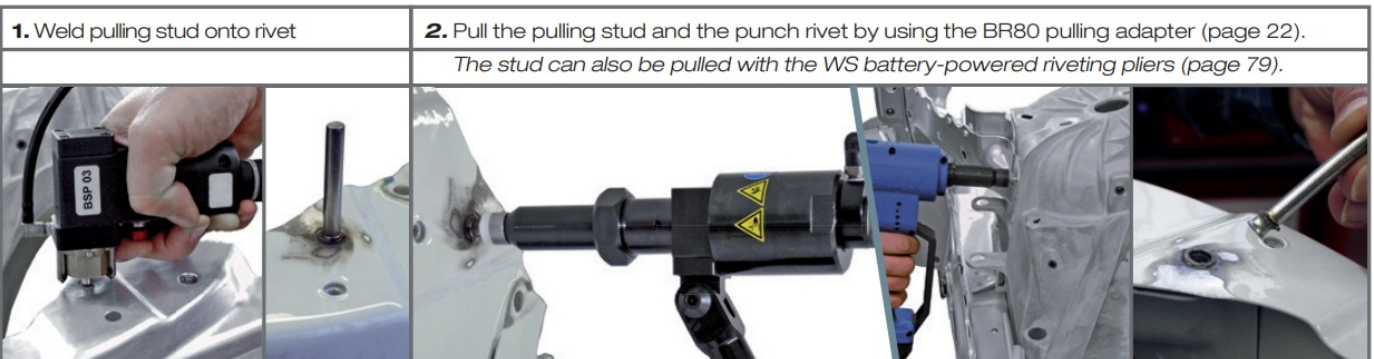

Adapter Kit BSP 03

Item no. 341002

This adapter set extends the range of application of the stud welder BSP 03 many times over. The contact pieces can be used to weld single balls, double balls, T-pins, thread welding studs and coarse threaded studs with the BSP03 welding gun onto body parts in the rear area or trunk. A practical tool is the placement tool for single, double ball and T-pins.



- Scope of delivery:
- 1 × contact piece N° 1 for single balls
 - 1 × contact piece N° 2 for double ball
 - 1 × contact piece N° 3 for T-pin
 - 1 × contact piece N° 4 for coarse thread bolt
 - 1 × contact piece N° 5 for thread welding bolt
 - 1 × equipping tool for contact pieces
 - 1 × gas attachment



Flammable coating set | content 8 pcs.

Item no. 341003

Scope of delivery: 1 x burner | 1 x burner stand | 2 x 50 ml Pyrosil® | 2 x 50 ml coupling agent | 2 x spatula

For the preparation of small to medium sized aluminium surfaces prior to the rivet-bonding process, prevents direct oxidation of the aluminium.

The manual flaming set is a surface silicatization tool that works on the principle of flame pyrolysis. In this process, a gas mixture of propane/butane and PYROSIL® (consisting of organosilicon compounds) burns in the flame and forms a SiO₂ layer on metal surfaces that is only a few nanometers thick but very dense and firmly adherent.



Pyrosil®
 coupling agent
 50 ml
 Item no. 347004



Pyrosil®
 refill cartridge
 27.5 g
 Item no. 347005



Item no.	341007	367085	347001
Description	rivet head drill bit 6.4 x 70 mm	pull rods V2A (for AK98) 4 x 35 mm	pull rods V2A-SA Ø 6 x 40 mm
QTY /	5 pcs. /	200 pcs. /	500 pcs. /



Accessories for BSP 03

Item no.	344005	344004	344003
Description	gun leg BSP 03	micro fuse F2 BSP 03 3.15 A slow	micro fuse F1 BSP 03 4.4 A slow
QTY /	4 pcs. /	1 pc. /	1 pc. /



WS Rivet tool cordless	Power supply	setting force	Weight
Item no. 571000	230 V 115 V	13 kN	5,3 kg

Riveting tool for opening the punch rivet joints - in connection with BSP 03 - and setting the special blind rivet joints. Also for the different work, head (nose pieces) are exchangeable.

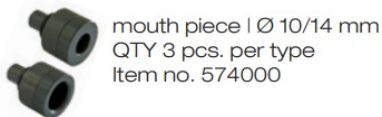

mouth piece | Ø 10/14 mm
 QTY 3 pcs. per type
 Item no. 574000



extension 100 mm
 Item no. 578114

Scope of delivery:
 1 x Powerbird cordless
 1 x Li-Ion charger 230 V 1ph
 2 x Li-Ion battery 14.4 V
 1 x gripping head for BSP03 (mounted)
 1 x gripping head Powerbird
 1 x mouthpiece rivet head Ø 14 mm (mounted)
 1 x mouthpiece rivet head Ø 10 mm
 1 x mouthpiece 17/45 mm Powerbird/Taurus



Aluminium crack testing

Item no.	311051	311050	311052
Description	Cleaner for test agent 400 ml	Penetration test fluid for aluminium cracks - 400 ml	Developer for test agent 400 ml
QTY /	1 pc. /	1 pc. /	1 pc. /

Test Stage 1 + 3 | Cleaner

The surface must be carefully cleaned **before and after** applying the penetration fluid.

Test stage 2 | Indicator

Spray on red liquid, waiting time approx. 15-20 minutes, after 20 min. wipe off with a cloth.

Test stage 3 | Developer

Spray the entire surface completely thin. Application time 20-30 min.



Temperature indication

Item no.	311062	311063	311064
Description	temperature indicator stick red melting point 100 °C	temperature indicator stick green melting point 204 °C	temperature indicator stick yellow melting point 400 °C
QTY /	1 pc. /	1 pc. /	1 pc. /

Application:

Mark the workpiece before or during heating. When the nominal temperature is reached, the marking melts (runs) and is clearly visible.



Item no.	311060	311061	311065
Description	Temp indicator strip with 6 points up to 160 °C	Temp indicator strip with 6 points up to 127 °C	temperature indicator stick blue melting point 500 °C
QTY /	10 pcs. /	10 pcs. /	1 pc. /

Apply indicator by applying light pressure to clean, grease-free surface. When the temperature threshold is reached, the color of the measuring point changes.

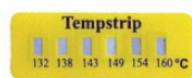

Landskit 2000 - mobile welding protection curtains stand

Item no. 881220

Fixed protective wall for welding work.
Lamella length 1800 mm with running clamps
ground clearance approx. 300 mm



colour orange



An advantage of welding curtains in orange is their transparency, which allows you to observe the welding process without suffering radiation damage to your eyes.

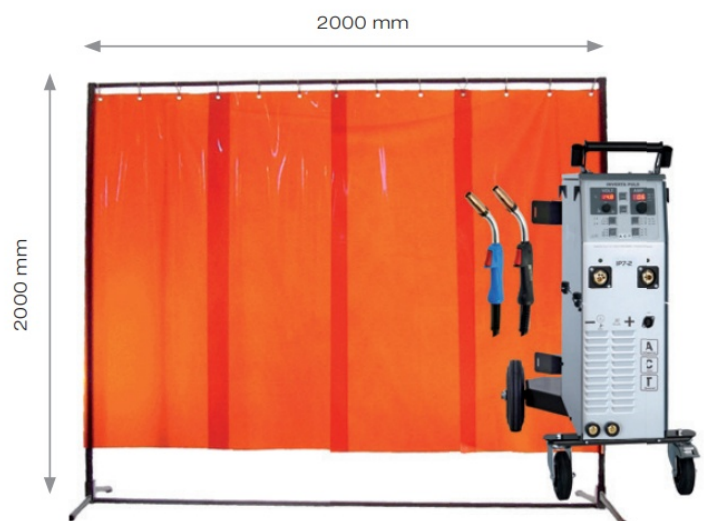

Item no.	311041	311026	311040
Description	special plier for gas welder with 4 functions	protection paste for gas nozzle 350 ml	cleaner kit 13 pcs. for current nozzle
QTY /	1 pc. /	1 pc. /	1 pc. /



For all welding nozzles. Fast and accurate trimming of the welding wire, time-saving cleaning of the shielding gas nozzle, pulling off the shielding gas nozzle, loosening and tightening the nozzle.



silicon-free

Prevents rapid clogging of the welding torches by welding spatter on gas and current nozzles.



12-piece nozzle cleaning needle kit in the practical, hinged metal box. With approx. 90 mm long needle files from Ø 0.4 to 1.6 mm including 1 flat file for cleaning welding nozzles.

Item no.	561030	311020	311048
Description	nipper plier weight 790 g	welding protection spray Trennfix silicon free, 400 ml	gas tester
QTY /	1 pc. /	1 pc. /	1 pc. /

Designed for disassembly work in car body repair.



Cutting edges are additionally hardened. Blade hardness approx. 59 HRC. Made of forged special tool steel, oil-hardened. The pliers are black atramentised with polished head.

Release agent and lubricant, very economical. Prevents rapid clogging of the welding torch by welding spatter on gas and current nozzles.



This gas flow tester is used to measure the flow rate of **Argon/CO2**. Due to the accuracy of its workmanship, it provides very precise results.



Item no.	881036	311044	311042
Description	welder gloves size XL	double branch valve 1/4" for manometer CO2 / Argon	ProControl, pressure regulator for CO2 / Argon / MIX and noble gas
QTY /	1 pair	1 pc. /	1 pc. /

Thick, flexible grained cowhide, oil and water resistant welder gloves. Padded back of the hand, palm unlined for better grip, sewn with 4 x kevlar thread. size XL, lenght 36 cm | 14"



up to gas purity 4.6
5 - 24 l/min adjustable outlet G 1/4" AG
inlet W21.8 x 1/14"
scale only for argon and CO2
max. cylinder pressure 200 bar
scale only for argon and CO2



Item no.	311043	374415	304053
Description	magnetic holder for torches	ground clamp without cable	ground clamp with cable 5 m
QTY /	1 pc. /	1 pc. /	1 pc. /



Welding protection blanket

Item no. 881011 1000 × 1000 mm

High Level Protection

Indispensable for welding, soldering and tinning

The collected welding drops do not penetrate the protective mat. Fire holes are thus effectively prevented. No health hazard as with asbestos mat setc.

Material: Tectalon® 1100 Niro / stainless steel Fabric core
max. temperature resistance **700 °C**



Spark protection blankets in 4 sizes

Item no.	881004	881003	881002	881001
Dimensions	1000 × 1000 mm	2000 × 1500 mm	2500 × 1250 mm	3000 × 2500 mm
QTY /	1 pc. /	1 pc. /	1 pc. /	1 pc. /

Material: stainless steel fabric core with max. temperature resistance **500 °C**

Advantages that pay off

Car windows splashed by flying sparks or paint damage, which are usually replaced at the cost of a garage, are many times more expensive than the purchase of the inexpensive and effective protective mats.



Spark protection blanket set

Item no.	882001	Welding bead catch	spark protection blanket	spark protection blanket
Dimensions	3 pcs.	1000 × 1000 mm	2000 × 1500 mm	2500 × 1250 mm
QTY /	1 set I	1 pc. incl.	1 pc. incl.	1 pc. incl.

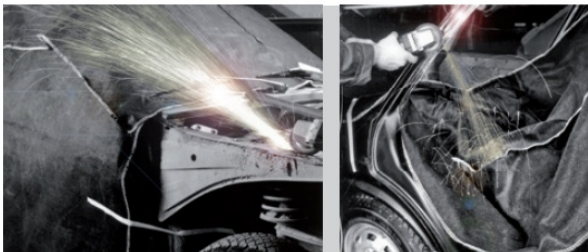

Grinding protection door cover

Item no. 881005 1000 × 1250 mm

Optimal protection for car doors

The material carbon fiber has the properties of high temperature resistance, is not flammable and a cloth-like soft handle guarantees easy handling. Hot, sharp-edged abrasive particles cannot penetrate the cloth material. Simply shake out after use.



Welding protection helmet **WS07 Pro**

Item no. 881047

Top features

- viewing window 30% larger than comparable models
- most modern sensor technology and automatic dimming
- variable blackout protection levels from # 9-13
- fastest reaction time - 0.00005 sec. (1/20.000)
- fine adjustment of the optical sensitivity
- adjustable rebrightening time min. 0.1 / max 1 sec
- 4 independent arc sensors
- automatic power saving shut-off after 20 min.
- extra wide and well padded headband reduces remarkably tiredness effects
- solar cells supported battery operation



Welding protection helmet **KAIMAN**

Item no. 881043

The **KAIMAN** auto-darkening welding helmet is suitable for all applications. It is equipped with 4 sensors, internal control and the **True Color** System, for a sharp and clear view, which allows the operator to distinguish easily the objects in the work area with lower eye strain.

Application areas:

- MIG-MAG (GMAW)
- WIG (GTAW) > 20 A
- electrode
- OXYGAS
- Grinder

NEW



Welding protection helmet **P850**

Item no. 881042

P850 is the entry-level auto-darkening welding helmet. It is perfect for those who want an affordable, reliable and aesthetic product. The helmet is provided with two darkening sensors and external regulation of the DIN grade. Provided with the True Color system, which ensures a clean and clear vision, it enables the operator to distinguish easily the objects in the work area with a lower eye strain. The external regulation allows the transition to the grinding modality without having to remove the helmet.

Perks:

- optical class 1/1/1/2
- field of view: 96 × 39 mm
- filter size: 110 × 90 × 9 mm
- 2 sensors
- response time < 0.3 ms
- external degree control DIN 4 / 9-13
- internal delay time 0.1 - 1.0 s
- internal sensitivity regulation
- battery supply + solar cells
- weight: 485 g

NEW



Spare parts WS07 Pro & accessories

Item no.	804048	884042	884043	884047
Description	auto darkening lens CP	replacement windscreen outside	replacement windscreen inside	battery CR2450
QTY /	1 pc. /	10 pcs. /	10 pcs. /	1 pc. /



Item no.	884044	884048	884050	884051
Description	head mounting kpl.	sweatband with velcro fastener	Athermal® welding glas A1 DIN 90 × 110 mm	front glass DIN /CE 90 × 110 mm
QTY /	1 pc. /	2 pcs. /	10 pcs. /	10 pcs. /



Proven welding protection glass according to DIN EN 166/169. For use in welding shields, head hoods or welding protection hoods. The glass is tinted in protection level DIN A11. Recommended protection levels for eye protection: Electrode welding: 50 - 149 A | MAG welding: 40 - 99 A | MIG welding: 80 - 174 A | MIG welding ALU sheets: 100-174 A | WIG welding: 100 - 174 A Hollow electrode: 80 - 124 A

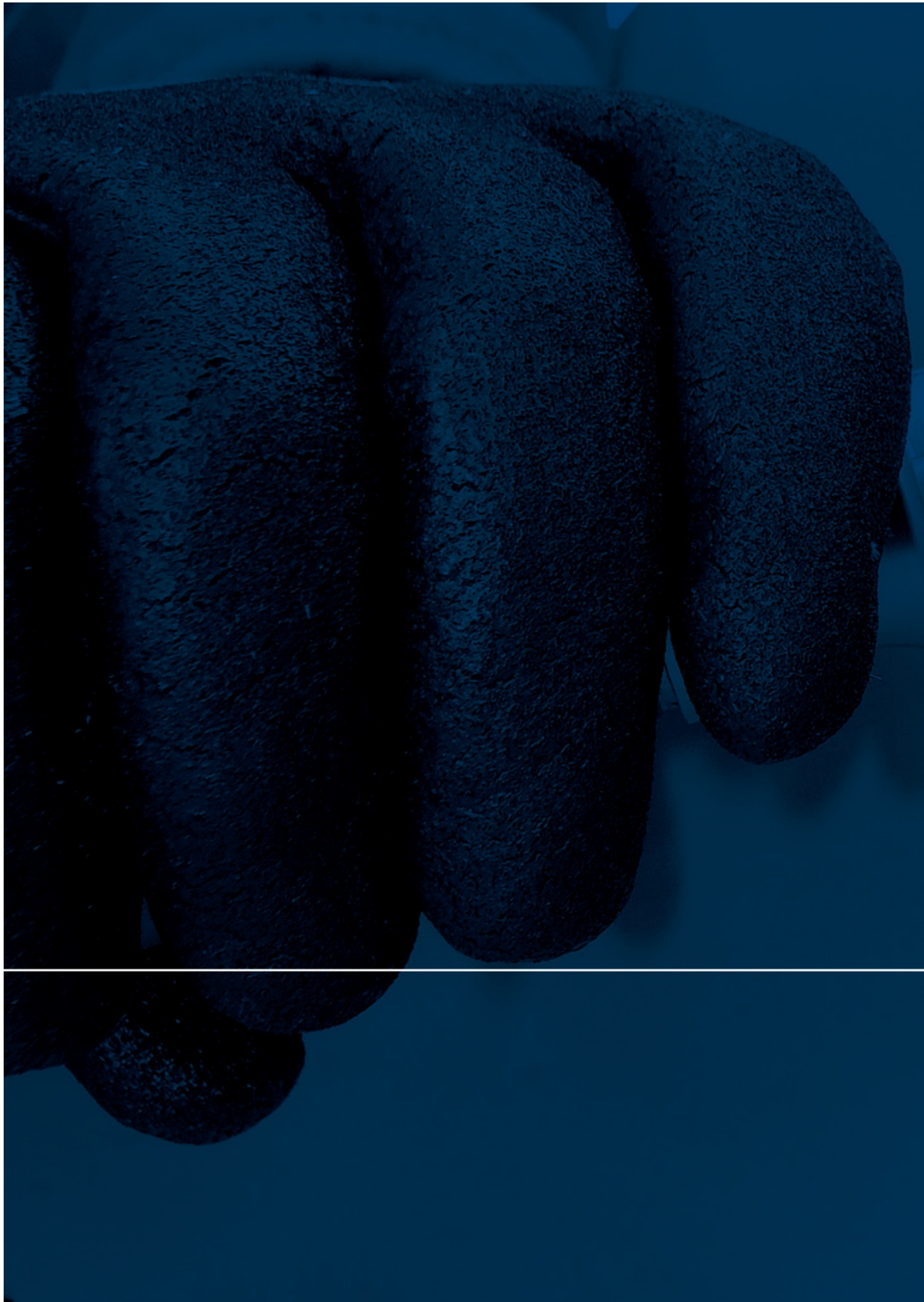



SEPARATING TOOLS

TABLE OF CONTENTS

MEC600	90
MEC600 cutters accessories lubricants	92
Pneumatic body saws	
WPS 2000	93
WPS 3000	93
Saw blades WPS 2000/3000	93
WPS 4000	94
Saw blades WPS 4000	94
Spare parts for WPS saws	94
Files WPS 2000/3000 WPF 3000	95
Accessories for pneumatic tools	
95	
Plasma Cutter WS 40i	96
Vario Drill WS90	97
G-Clamps	98
Extensions	98
Centring attachments	98
Cutting oil	98
Milling cutters	99
Solid carbide drill bits	100
Centre punches	100
Drilling tools	
Drilling machine GTC-041B	101
Drill bits for spot weld removal	101
BTR / BOR Milling cutters	101
Countersinks	102
Special drill bits for rivets	102
Drill bit sets	102
Drilling tool BWZ 100	103
Drilling templates BWZ 100	103
Temporary fasteners	103
Laser-Cutter LC 04	104
Accessories	104
Spare parts	105
Grinders	
Angle grinders Straight grinders	106
High speed burrs	106
Solid carbide burrs	107
Cut-off wheels Grinding discs	107
Air Rubber AR 06	108
Belt sander	108
File belts Abrasive belts	108
Disc sander GTC-412S	108
Angle grinder FX-8125LA	108
Pistol grinder S 317	109
Accessories for discontinued tools	
Brush grinder Eraser 4000	109
Angle grinder DG22	109
Cleaning fleece discs	109





MEC600[®]

METAL EDGE CUTTER

- car roofs
- c-pillars
- wheel arches
- door areas
- sills



The MEC600 was developed for process-safe and precise car body outer skin removal. The metal structure under the outer skin remains undamaged in the process.





aluminium 1.2 mm

steel 0.8 mm

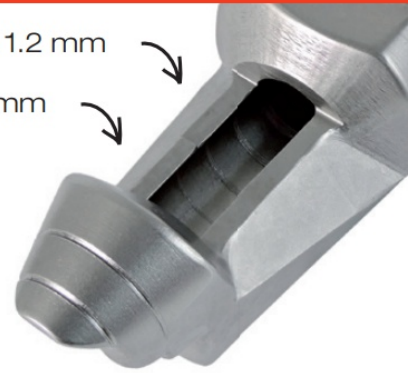

Two different milling depths for aluminium and steel sheets ensure that only the necessary amount is milled off the wheel arch, depending on the material, to avoid damaging the inner sheet.

MATERIAL SPECIFIC MILLING DEPTH

VARIABLE ANGLE POSITIONS



PRECISE ADJUSTMENT OF THE MILLING DEPTH

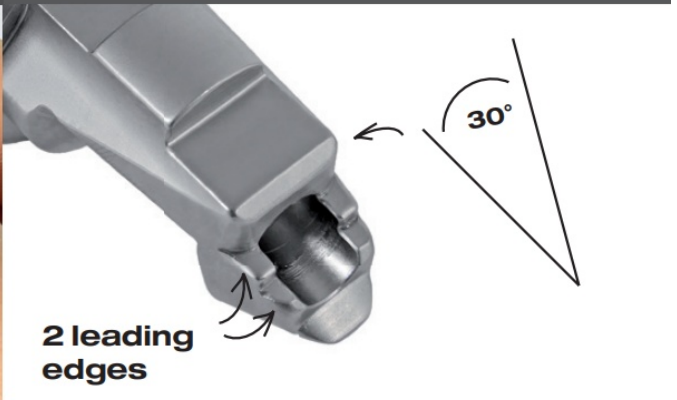

2 leading edges

The adjustable guide of the cutter allows quick and easy adjustment of the MEC600 to different angular positions of the body panels.

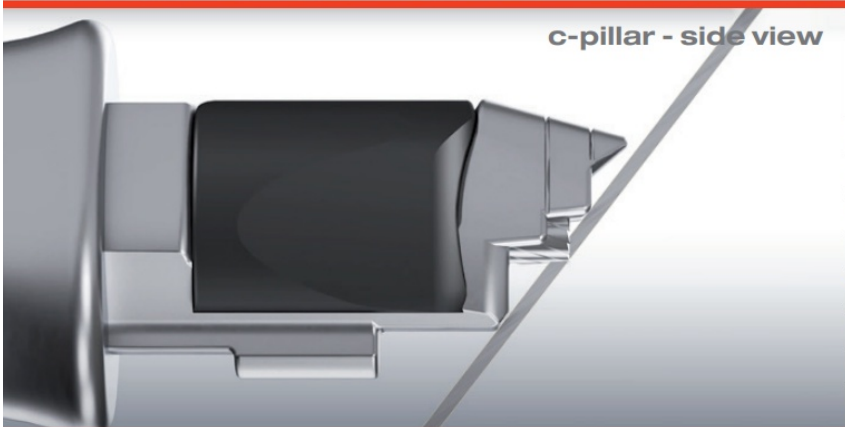

TECHNICAL DATA

Pressure	6.3 bar max.
Power	600 W
Idle Speed	20,000 rpm
Sound pressure level	77 dB(A)
Vibration	3.6 m/s ²
Cable-hose assembly	3,100 mm
C-ollet chuck	Ø 6 mm
Weight	2.05 kg

MEC600 Metal Edge Cutter

Item no. 640080

- no damage to the deeper sheet metal structure
- milling depths continuously adjustable
- innovative carbide special cutters for steel and aluminium
- high application safety when opening laser welded seams (Plasmatron welding)
- no sparks - in combination with cutting oil (BTR fluid)
- no heat pre-treatment on the car body necessary
- quick tool change

Scope of delivery:

- 1 x basic unit pneum. cpl.
- 1 x machine attachment MEC600
- 1 x locking nut MEC600
- 1 x milling cutter **LongLife** (for steel sheets)
- 1 x gauge MEC600
- 1 x protective cover
- 1 x allen key
- 1 x instruction manual



MEC600 Milling Cutter

Item	LongLife	LSN Laser welded seam	carbide cutter for ALU
Ø	6 mm	6 mm	6 mm
Item no.	640063	640069	640062



MEC600 Accessories

Item	machine attachment V2	locking nut	gauge	protective cover
			for optimum milling depth Sheet thickness 0.6 to 1.5 mm	finger protection during milling
Item no.	640053	640057	640052	640051



MEC600 Lubricant

Item	cutting oil	Drill WAX
	125 ml for steel	65 g for aluminium milling cutters
Item no.	628000	640067



WPS 2000 – Pneumatic Saw

Item no. 120010

Designed for a wide range of applications and the daily cutting and separating work in car body construction. 12,000 strokes per minute ensure burr-free cutting.

Scope of delivery:

- 1 × WPS 2000 pneum.
- 1 × saw blade 14 tpi
- 1 × saw blade 18 tpi
- 1 × saw blade 24 tpi
- 1 × saw blade 28 tpi (mounted)
- 1 × saw blade 32 tpi
- 1 × compressed air hose with air connection
- 2 × assembly tool
- 1 × transport case
- 1 × instruction manual



WELL-ESTABLISHED

Stroke	Power	Vibration	Stroke rate	Weight	Length
8 mm	310 W	24 m/s ²	12,000 spm	810 g	220 mm

WPS 3000 – Pneumatic Saw

Item no. 120030

The long 10 mm stroke results in perfect cutting performance and reduced sound pressure level 77.4 dB(A) according to ISO 15744. The saw meets the standards of the Employer's Liability Insurance Association for Occupational Safety and is designed for continuous operation.

Scope of delivery:

- 1 × WPS 2000 pneum.
- 1 × saw blade 14 tpi
- 1 × saw blade 18 tpi
- 1 × saw blade 24 tpi
- 1 × saw blade 28 tpi (mounted)
- 1 × saw blade 32 tpi
- 1 × compressed air hose with air connection
- 2 × assembly tool
- 1 × transport case
- 1 × instruction manual



LOW-VIBRATION

< 2.5 m/s² according to ISO 8662

Stroke	Power	Vibration	Stroke rate	Weight	Length
10 mm	300 W	< 2.5 m/s ²	12,000 spm	830 g	280 mm

Saw Blades – Bimetal

body saws WPS 2000 / WPS 3000

Item no.	Tpi*	Application	QTY
197000	14	wood, aluminium, composites, plastic	10 pc.
197001	18	for tight radii in metal and plastic	10 pc.
197002	24	double and triple sheets up to 4 mm	10 pc.
197004	28	thin, double sheets and aluminium up to 3 mm	10 pc.
197003	32	universal saw blade thin sheets and high-strength steels up to 1 mm	10 pc.
Item no.	tpi*	Item	QTY
197007	18	M42-18	3 pc.
197008	24	M42-24	3 pc.



Info

*tpi = teeth per inch

WPS 4000 – Pneumatic Saw

Item no. 120050

the cold type of separation

The WPS 4000 is the powerhouse specially developed for demanding requirements and is particularly well suited for extremely hard and tough materials.

USIBOR - BTR - TRIP - ZSTE - Ultra HSS - HSS - HLE - THLE - TTHLE
Aluminium - Casting - Extrusion etc.

Scope of delivery:

- 1 x WPS 4000 pneum.
- 1 x saw blade M42 | 10 tpi | 100 mm
- 1 x saw blade MPM | 8 tpi | 100 mm
- 1 x saw blade TCT | 18 tpi | 100 mm
- 1 x compressed air hose with air connection
- 1 x assembly tool
- 1 x transport case
- 1 x instruction manual



CONCENTRATED POWER

Stroke	Power	Vibration	Stroke rate	Weight	Length
20 mm	400 W	27 m/s ²	7,000 spm	1.28 kg	290 mm

Saw Blades – Bimetal

body saws WPS 4000

Item no.	Tpi*	Item	L=mm	Application	QTY
197024	10	M42	130	aluminium, composites	1 pc.
197025	10	M42	100	aluminium, composites	1 pc.
197023	18	MPM	130	high-strength steels	1 pc.
197026	18	MPM	100	high-strength steels	1 pc.
197027	18	TCT	90	ultra high strength steels	1 pc.
197028	-	TCT Plus	90	ultra high strength steels	1 pc.



Info

*tpi = teeth per inch

Spare Parts WPS 2000 / WPS 3000 / WPS 4000

Item no.	124027	124127	194070
Item	tool holder cpl. WPS 2000 / 3000	tool holder cpl. WPS 4000	tool holder clamp bridge cpl. WPS 2000 / 3000 / WPF 3000
QTY /	1 pc. /	1 pc. /	1 pc. /



Special / Universal Saw Blades

Item no.	Tpi*	Item / application	QTY
197010	-	diamond saw blade suitable for e.g. CFRP / carbon	1 pc.
197005	24	saw blade with flat mount**	10 pc.
197006	32	saw blade with flat mount**	10 pc.



Info

** suitable for saws e.g. type Chicago Pneumatic

WPF 3000 – Pneumatic File

Item no. 120040

Due to the ability to adjust the stroke length, it is possible to freely regulate the frequency, which results in a wide range of applications. Due to the high accessibility, especially in narrow places, the file is ideal for deburring, shaping and prototyping.

CAN ALSO BE USED WITH SAW BLADES



Scope of delivery:
 1 x WPF 3000 pneum.
 1 x compressed air hose with air connection
 2 x assembly tool
 1 x transport case
 1 x instruction manual

STROKE LENGTH ADJUSTMENT

Stroke	Power	Vibration	Stroke rate	Weight	Length
6-8 mm	300 W	< 2.5 m/s ²	12,000 - 20,000 spm	830 g	280 mm

Files WPS 2000 / WPS 3000 / WPF 3000

Item no.	Length (mm)	Item	QTY
197040	90/55	file - half round 	1 pc.
197041	90/70	file - round 	1 pc.
197042	90/60	file - triangular 	1 pc.
197039		file set - 3 pieces, half round, round, triangular 	3 pc.

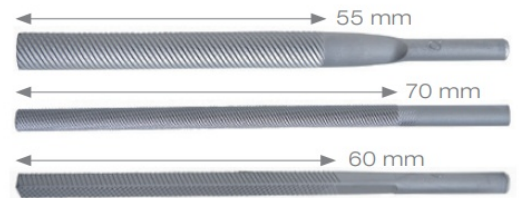

Accessories for Saws & Pneumatic Tools

Item no.	194000	637103	697003	697002	698007
Item	pressure reducing valve to max. 7 bar	mini lubricator for air tools connection 1/4"	air connection 1/4" (external thread)	brass coupler with nozzle 9 mm	pressure reducer 1/4" (internal thread)
QTY /	1 pc. /	1 pc. /	1 pc. /	1 pc. /	1 pc. /



Special Oil for Pneumatic Maintenance Units | 1000 ml

Item no. 698001

High-performance oil for use in oil-fog lubricators and maintenance units, also for tools and pneumatic systems according to DIN 51524-2.

viscosity class VG 32 according to ISO 3448 (viscosity at 40 °C - 32 mm²/s)

Exceeds the minimum requirement for hydraulic oils of type HLP.

Increased ageing resistance and active corrosion or wear protection provide high utility value throughout the entire service life. Good viscosity/temperature characteristics even at low temperatures as well as optimum demulsibility.



with lateral content indicator and practical filler hose



PRECISE & BURR-FREE CUTS

SPECIAL PROGRAM FOR SURFACES WITH PAINT RESIDUES OR SOILING

CUTTING ACROSS SHEET METAL GAPS

SHEET METAL CUT UP TO 8 MM

ROUGH CUT UP TO 15 MM

PLASMA CUTTER WS 40i

Latest generation technology

High-performance control for a stable arc for smooth and straight cuts with approximately 50% less ignition energy than comparable models, provides increased service life for current nozzles, cutting nozzles and torches.

Plasma Cutter WS 40i

Item no. 171005

Mains voltage	Welding current	Continuous output	Material thickness	Weight
230 V 50/60 Hz	10–30 A	23 A	< 8 mm (< 15 mm)	14.5 kg

Scope of delivery:

- 1x WS40 i control unit
- 1x Cutting torch S25/4 m
- 1x ground cable with ground clamp
- 1x instruction manual

USA version - Item no. 171006



Accessories WS 40i

Item no.	174004	174016	177008
Item	hand torch assembly cpl. WS40 i	ground cable WS40 i	guiding carriage for torch WS40i
QTY /	1 pc. /	1 pc. /	1 pc. /



Spare Parts WS 40i

Item no.	Ø	Item	QTY
177001		short electrode	10 pc.
177003	0.8 mm	short cutting nozzle	10 pc.
177006		ceramic nozzle - 39 mm	2 pc.





EFFORTLESS

PRECISE

**CONTINUOUSLY ADJUSTABLE
MILLING DEPTH**

QUICK AND SIMPLE ASSEMBLY

WITH DEPTH STOP

**FOR HIGH-STRENGTH AND
SUPER HIGH-STRENGTH
MATERIALS**

Spot weld remover for all vehicles

Convenient work even in hard-to-reach places thanks to simple, tool-free removal of the Variomatic handle. The 360° rotatable Variomatic handle prevents slipping and the depth stop prevents the underlying sheet metal from being damaged.

VARIO DRILL WS90

Vario Drill WS90 with Variomatic

Item no. 601001

working area: 95 x 35 mm

Speed	Power	Vibration	Operating pressure	Weight
900 rpm	370 W	1.07 m/s ²	6–8 bar	1.8 kg

Scope of delivery:

- 1 x VARIO DRILL WS90
- 1 x Variomatic
- 1 x VARIANTIC milling cutter Ø 8 mm
- 1 x pin wrench
- 1 x transport case



Vario Drill WS90 with Jumbomatic

Item no. 601009

working area: 140 x 85 mm

Scope of delivery:

- 1 x VARIO DRILL WS90
- 1 x Jumbomatic
- 1 x VARIANTIC milling cutter Ø 8 mm
- 1 x pin wrench
- 1 x transport case



Vario Drill WS90 without Variomatic



Item no. 602001

Scope of delivery:

- 1 x VARIO DRILL WS90
- 1 x VARIANTIC milling cutter Ø 8 mm
- 1 x pin wrench
- 1 x transport case



VarioDrill WS90 Clamps

Item no.	608020	608018	608019
Item	Variomatic	Jumbomatic	Jumbomatic Daimler version
QTY /	1 pc. /	1 pc. /	1 pc. /
			
			Nur in Verbindung mit 607101 ↓

Crown Cutter Special

Item no. 607101

diameter: 14 mm

Scope of delivery:
1 x cutting head with mandrel
1 x spring + holding pin
3 x special crowns



Spare Crown

Item no. 607110

type N

diameter: 14 mm



Extensions for Vario Drill WS90

Item no.	608012	608010	608011
Item	VD 305	135 mm	85 mm
Length	305 mm	135 mm	85 mm
QTY /	1 pc. /	1 pc. /	1 pc. /



Centering Attachments for Vario Drill WS90

Item no.	608001	608002	627001
Item	V1 top side	V2 bottom side	drill bit NK-2F
	<i>only for solid carbide drill bits 627001</i>	<i>only for solid carbide drill bits 627001</i>	3 cutting edges head-Ø: 6.7 mm shank-Ø: 8 mm total length: 44 mm
QTY /	1 pc. /	1 pc. /	1 pc. /



for **HSS | UHSS**
for the removal of self piercing rivets



BTR - Fluid

silicone free cutting oil

A silicone-free special oil that reduces friction during the cutting process and ensures a longer service life of the tool.

Item no.	648007	628000
Item	50 ml	125 ml
QTY /	1 pc. /	1 pc. /



BTR/BOR Starter Kit

Item no. 622003

Scope of delivery:

- 1 × 620002 for **HSS | UHSS**
- 3 × 620205 for **Steel | HSS**
- 1 × centre punch
- 1 × BTR-Fluid 125 ml



BTR/BOR Milling Cutters Set

Item no. 620116

3 cutting edges

Scope of delivery:

- 2 × 620000 for **HSS | UHSS**
- 2 × 620002 for **HSS | UHSS**
- 2 × 620006 for **HSS | UHSS**
- 1 × centre punch



Spot Weld Cutters

Item no.	607001	607011		607013	607023		607021
Item	VAPO	TIN-GOLD		VAPO	TICN		VAPO
Suitable for	Steel	Steel		Steel	Steel		Steel
RPM (min ⁻¹)	795-995	795-995		795-995	795-995		708-885
Head-Ø	6 mm	8 mm		8 mm	8 mm		9 mm
Shank-Ø	8 mm	8 mm		8 mm	8 mm		8 mm
Total length	44 mm	44 mm		44 mm	44 mm		44 mm
Cutting edges	2	2		2	2		2
QTY	1 pc.	1 pc.		1 pc.	1 pc.		1 pc.



BTR / BOR Milling Cutters

Item no.	620000	620001	620002	620005	620006
Suitable for	HSS UHSS	HSS UHSS	HSS UHSS	HSS UHSS	HSS UHSS
RPM (min ⁻¹)	795-995	795-995	795-995	705-885	640-795
Head-Ø	6 mm	8 mm	8 mm	9 mm	10 mm
Shank-Ø	8 mm	8 mm	8 mm	8 mm	8 mm
Total length	44 mm	44 mm	44 mm	44 mm	44 mm
Cutting edges	3	3	3	3	3
QTY	1 pc.	1 pc.	3 pc.	1 pc.	1 pc.



Variatic Milling Cutters

Item no.	620200	620205	620206
Suitable for	Steel HSS	Steel HSS	Steel HSS
RPM (min ⁻¹)	795-995	795-995	795-1115
Head-Ø	8 mm	8 mm	10 mm
Shank-Ø	8 mm	8 mm	8 mm
Total length	44 mm	44 mm	44 mm
Cutting edges	3	3	3
QTY	1 pc.	5 pcs.	1 pc.



BESTSELLER



Solid Carbide Drill Bits

3 cutting edges

4 cutting edges

The ultra high strength solid carbide drills Z4 remove spot welds even from the hardest materials.

USIBOR • BORON • BTR • ZSTE • Trip steel

Item no.	627005	627010	627020	627021	627022
Suitable for	HSS UHSS	HSS UHSS	HSS UHSS	HSS UHSS	HSS UHSS
RPM (min ⁻¹)	795-995	795-995	795-995	708-885	635-795
Head-Ø	5 mm	6.7 mm	8 mm	9 mm	10 mm
Shank-Ø	8 mm	8 mm	8 mm	8 mm	8 mm
Total length	49 mm	49 mm	44 mm	44 mm	44 mm
Cutting edges	3	3	4	4	4
QTY	1 pc.	1 pc.	1 pc.	1 pc.	1 pc.



BESTSELLER



Centre Punches

Item no.	628006	628007
Item	special centre punch 2 functions	centre punch 5 × 120 mm
QTY /	1 pc. /	1 pc. /

function 1: marks the centre of the rivet from the top side
function 2: marks the centre of the rivet from the bottom side
the center punch centers itself



Centre Punches

Item no.	628005	932521
Item	UHSS-centre punch	automatic centre punch
QTY /	1 pc. /	1 pc. /



BESTSELLER



Drilling Machine GTC-041B

Item no. 611122

Pneumatic drill with clockwise / counter-clockwise rotation and quick-action chuck.



Speed	Power	Vibration	Operating pressure	Weight
450 rpm	340 W	2.5 m/s ²	6 bar	1.75 kg

Drill Bits for Spot Weld Removal

Item no.	617011	617014	617021
Item	VAPO	TIN-GOLD	VAPO
Suitable for	Steel	Steel	Steel
RPM (min ⁻¹)	1195-1395	1195-1395	955-1115
Head-Ø	8 mm	8 mm	10 mm
Shank-Ø	8 mm	8 mm	10 mm
Total length	80 mm	80 mm	85 mm
Cutting edges	2	2	2
QTY	1 pc.	1 pc.	1 pc.

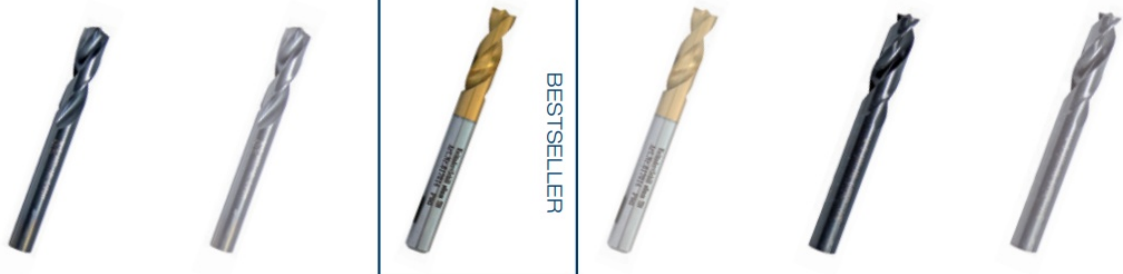

BTR / BOR Milling Cutters

Item no.	620010	620011	620012	620014	620015	620017	620018	620022	620024	620040	620026	620030
Suitable for	HSS UHSS	HSS UHSS	HSS UHSS	HSS UHSS	HSS UHSS	HSS UHSS	HSS UHSS	HSS UHSS	HSS UHSS	HSS UHSS	HSS UHSS	HSS UHSS
RPM (min ⁻¹)	≥ 2120 ≤ 2650	≥ 2120 ≤ 2650	≥ 1820 ≤ 2275	≥ 1590 ≤ 1990	≥ 1500 ≤ 1830	≥ 1340 ≤ 1680	≥ 1270 ≤ 1590	≥ 1060 ≤ 1320	≥ 980 ≤ 1220	≥ 945 ≤ 1180	≥ 910 ≤ 1130	≥ 800 ≤ 990
Head-Ø	3 mm	3.2 mm	3.5 mm	4 mm	4.2 mm	4.8 mm	5 mm	6 mm	6.5 mm	6.7 mm	7 mm	8 mm
Shank-Ø	8 mm	8 mm	8 mm	8 mm	8 mm	8 mm	8 mm	8 mm	8 mm	8 mm	8 mm	8 mm
Total length	70 mm	70 mm	70 mm	70 mm	70 mm	70 mm	70 mm	70 mm	70 mm	70 mm	70 mm	70 mm
Cutting edges	3	3	3	3	3	3	3	3	3	3	3	3
QTY	1 pc.	1 pc.	3 pc.	1 pc.	1 pc.	1 pc.	1 pc.	1 pc.	1 pc.	1 pc.	1 pc.	1 pc.



BTR/BOR milling cutter for use with the SPOTLE pneum. spot weld remover

3 cutting edges

Item no. 620130

Head-Ø	8.0 mm
Shank-Ø	8.0 mm
Total length	39 mm
QTY	1 pc.



Countersinks

Item no.	617240	617241
Item	countersink 120° with depth stop and pilot	countersink 100° with depth stop and pilot
QTY /	1 pc. /	1 pc. /



INITIAL USE: **MERCEDES-BENZ**



INITIAL USE: **PORSCHE**

Spare Parts for Countersinks

Item no.	617243	617244	617245	617246	617247
Item	spare countersink 100°	spare countersink 120°	spare pilot 4 mm for countersink 120°	spare pilot 6.3 mm for countersink 120°	spare pilot 6.6 mm for countersink 100°
RPM (min ⁻¹)					
QTY /	1 pc. /	1 pc. /	1 pc. /	1 pc. /	1 pc. /



Special Drill Bits for Rivets

Item no.	617220	617221	617222	617226	617227	617228
Item	TIN	TIN	TIN	TIN	TIN	TIN
Suitable for	Alu Steel	Alu Steel	Alu Steel	Alu Steel	Alu Steel	Alu Steel
RPM (min ⁻¹)	2390-3980	2390-3980	1910-3180	1600-2650	1470-2450	1350-2250
Head-Ø	4.1 mm	4.2 mm	5.1 mm	6.1 mm	6.5 mm	6.7 mm
Shank-Ø	4.1 mm	4.2 mm	5.1 mm	6.1 mm	6.5 mm	6.7 mm
Total length	70 mm	70 mm	85 mm	100 mm	100 mm	100 mm
Cutting edges	2	2	2	2	2	2
QTY	1 pc.	1 pc.	1 pc.	1 pc.	1 pc.	1 pc.

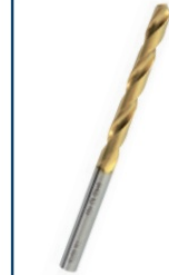

BESTSELLER



Drill Bit Sets

	Step drill bit set 3-piece set	Drill bit set 19-piece set
	no. 1: 1-14 mm no. 2: 8-20 mm no. 3: 16-30.5 mm	Ø 1-10 mm 0.5 mm steps
Item no.	617300	637004
QTY /	1 pc. /	1 pc. /

Can be used on non-ferrous metals, stainless steel sheets, thermoplastic and thermo-setting plastics as well as on all common steel sheets up to a thickness of max. 4 mm. With step drill bits, sheets can be centered, tapped and drilled out in one operation.





EFFORTLESS

EASY ATTACHMENT DUE TO THE MAGNETIC HOLDING SYSTEM

LIGHT METAL HOUSING WITH ERGONOMIC HANDLES

GOOD ACCESSIBILITY AND GOOD VIEW ONTO THE DRILL BIT

REDUCED DRILL WEAR DUE TO VERTICAL TOOL APPROACH

Drilling in extreme situations

The BWZ 100 is mounted vertically on the sheet with the magnetic feet, minimizing the amount of force required. The built-in feed system ensures less drill wear.

DRILLING TOOL BWZ 100

BWZ 100

Item no. 611110

Speed	Power	Vibration	Operating pressure	Weight
950 rpm	280 W	<2.5 m/s ²	6-8 bar	4.4 kg

Scope of delivery:

- 1 x BWZ 100 drilling tool
- 1 x special drill Ø 6.7 mm; 48/11 mm (620050)
- 1 x BTR fluid 50 ml
- 1 x allen key SW 2
- 1 x transport case
- 1 x instruction manual

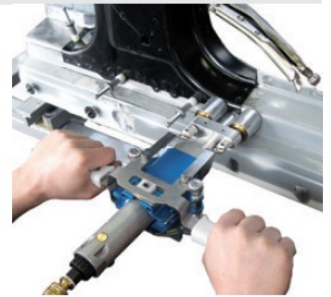

BWZ 100 - drill for Mercedes riveting process preparations

3 cutting edges

Item no. 620050

Head-Ø	6.7 mm
Shank-Ø	8.0 mm
Length of head	11 mm
Total length	48 mm
QTY	3 pc.



Special Accessories

Item no.	577107	932410
Item	temporary fasteners	drilling templates BWZ 100
	Ø 6.35 mm	MB type C216 + W/V221
QTY /	20 pc. /	1 set (7 pc.) /



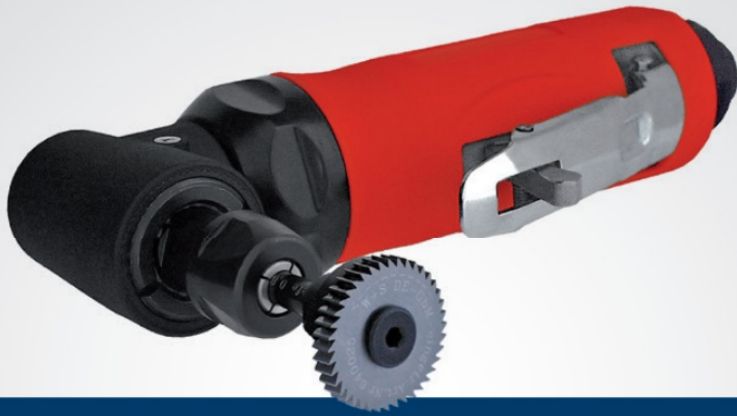

**FOR LASER WELDING SEAMS &
LASER SOLDERING SEAMS**

**CUTTING DEPTH LIMITATION OF
0.8 OR 1.0 MM**

VERY LIGHTWEIGHT

VERY ACCURATE CONCENTRICITY

**GOOD ACCESSIBILITY DUE TO
COMPACT DESIGN**

Clean milling of the laser seams

The newly developed cutting wheel with innovative duplex sharpening is made of special solid carbide and ensures precise milling. Due to its compact design, the LC 04 is easy to handle and allows good accessibility even in narrow places.

LASER-CUTTER LC 04

Laser-Cutter LC 04

Item no. 640000

Speed	Vibration	Operating pressure	Air consumption	Weight
18,000 rpm	< 0.9 m/s ²	6–8 bar	500 l/min	0.85 kg

Scope of delivery:

1 x LC 04 basic machine	1 x aluminum clamping ring
1 x mandrel 25 0.8 mm	1 x guide arm
1 x mandrel 25 1.0 mm	2 x allen key
1 x LC 04 cutting wheel - solid carbide Ø 25 x 4 mm	1 x cutting oil 50 ml
1 x protective cover - cutting wheel Ø 25 mm	1 x transport case



Accessory Set | Laser-Cutter LC 04

Item no. 642000

Scope of delivery:

1 x LC 04 cutting wheel - solid carbide Ø 40 x 4 mm
1 x mandrel 40 mm | 0.8 mm
1 x mandrel 40 mm | 1.0 mm
1 x protective cover - cutting wheel Ø 40 mm



Side Milling Cutter | AluCut | 40 x 4.4 mm

Item no. 637117

For milling of all types of aluminium

- especially for aluminium
- extremely precise removal of weld seams due to special toothing
- special arbor with "drive pin"
- for all common straight and angle grinders with a 6 mm diameter mount

Scope of delivery:

2 x SK AluCut side milling cutters
1 x mandrel SK AluCut Ø 6 mm



Mandrels

Item no.	640005	640010	640015	640020
For cutting disk-Ø	25 mm		40 mm	
Depth of cut	0.8 mm	1 mm	0.8 mm	1 mm
QTY	1 pc.	1 pc.	1 pc.	1 pc.



Cutting Wheels

Item no.	640025	640030
Material	solid carbide	
Thickness	4 mm	
Diameter	25 mm	40 mm
QTY	1 pc.	1 pc.



Protective Covers

Item no.	648000	648005
Material	transparent glass	
For cutting disk-Ø	25 mm	40 mm
QTY	1 pc.	1 pc.



Guide Arm | Laser-Cutter LC 04

Item no. 648015



Mini Angle Grinder | pneumatic

Item no. 611003

Speed	Vibration	Operating pressure	Air consumption	Weight
72,000 rpm	2.0 m/s ²	6.3 bar	150 l/min	0.23 kg



High Speed Burrs

Material	solid carbide			HSS		
Shape	ball	pointed cone	ball	ball	disk	cylinder
Head size	Ø 5 mm	3.2 × 5.6 mm	Ø 2.3 mm	Ø 6 mm	12 × 2.6 mm	6 × 10 mm
Shank-Ø	3 mm	3 mm	3 mm	3 mm	3 mm	3 mm
QTY	1 pc.	1 pc.	1 pc.	1 pc.	1 pc.	1 pc.
Item no.	637000	637120	637121	637122	637123	637124



LC 04 Angle Grinder | pneumatic

Item no. 631003

Speed	Vibration	Operating pressure	Air consumption	Weight
18,000 rpm	< 0.9 m/s ²	6-8 bar	85 l/min	0.89 kg



Straight Grinder | pneumatic

Item no. 631002

Speed	Vibration	Operating pressure	Air consumption	Weight
20,000 rpm	< 0.9 m/s ²	6-8 bar	85 l/min	0.87 kg



Tool Holder

Item no. 637020

Shank diameter	Suitable for cut-off wheels with bore diameter	Suitable for cut-off wheels with thickness
6 mm	6 mm	0-4 mm



Solid Carbide Burrs				Solid Carbide Burrs for Aluminium		
Item no.	637001	637002	637003	637010	637011	637012
Head-Ø	10 mm	12 mm	12 mm	12 mm	12 mm	12 mm
Length of head	20 mm	10.8 mm	25 mm	25 mm	10 mm	30 mm
Shank-Ø	6 mm	6 mm	6 mm	6 mm	6 mm	6 mm
Total length	60 mm	51 mm	65 mm	65 mm	51 mm	70 mm
QTY	1 pc.	1 pc.	1 pc.	1 pc.	1 pc.	1 pc.



Mini Cut-Off Wheels				
Item no.	637021	637022	637023	637024
Internal bore	6 mm	6 mm	6 mm	6 mm
Ø	30 mm	50 mm	50 mm	50 mm
Disk thickness	1.1 mm	1.1 mm	2.1 mm	0.8 mm
QTY	50 pc.	50 pc.	50 pc.	50 pc.



Cut-Off Wheels and Tool Holder Set

Item no. 637025

Scope of delivery:
 1 x tool holder art. no. 637020
 10 x cut-off wheel 30 mm x 6 mm bore
 10 x cut-off wheel 50 mm x 6 mm bore



Grinding Disks CSD

Item no. 612010

Gentle removal of paint and dirt from sheet metal.
 Leaves a completely cleaned surface for the next phase of the process; coating, painting or soldering.

Scope of delivery:
 1 x mandrel art. no. 618011
 2 x grinding disk CSD art. no. 617080



Grinding Disks CSD

Item no. 617080

Diameter	Disk thickness	Bore
100 mm	13 mm	12 mm



Mandrel for CSD Grinding Disks

Item no. 618011

Diameter up to	Disk thickness up to	Bore
150 mm	13 mm	12 mm



Air Rubber AR 06 | pneumatic

Item no. 631030

For the removal of films and adhesive residues from painted surfaces.

Scope of delivery:

1 x Air Rubber Ar 06

1 x air rubber disk Ø 87 mm art. no. 637050



Air Rubber Disk | Ø 87 mm

Item no. 637050

For the removal of films and adhesive residues from painted surfaces.



Belt Sander | pneumatic

Item no. 671001

- **for sanding belts 10 x 330 mm**
- especially suitable for narrow surfaces
- continuously variable speed adjustment
- belt quick change system
- automatic belt adjustment

Speed	Power	Vibration	Operating pressure	Weight
10,500-16,000 rpm	373 W	2.5 m/s ²	6.3 bar	1.06 kg



File Belts

Item no.	Width	Length	Grit	QTY
677007	10 mm	330 mm	K 36	10 pc.
677008	10 mm	330 mm	K 60	10 pc.
677009	10 mm	330 mm	K 80	10 pc.



Abrasive Belts

Item no.	Width	Length	Grit	QTY
677011	10 mm	330 mm	K 80	10 pc.
677012	10 mm	330 mm	K 40	10 pc.
677013	10 mm	330 mm	K 60	10 pc.

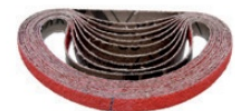

Disk Sander GTC-412S | 1.4" | pneumatic

Item no. 611121

for grinding disks with the diameter 178 mm

Info: The scope of delivery does not include the disk holder

Speed	Power	Vibration	Operating pressure	Weight
4,500 rpm	520 W	2.5 m/s ²	6 bar	2.0 kg



Angle Grinder FX-8125LA | 1.4" | pneumatic

Item no. 611135

Speed	Power	Vibration	Operating pressure	Weight
9,500 rpm	745 W	4.4 m/s ²	6 bar	1.8 kg



Pistol Grinder S 317 | 5" | pneumatic

Item no. 611124

for sanding pads with diameter 127 mm

Speed	Power	Vibration	Operating pressure	Weight
16,000 rpm	300 W	2.9 m/s ²	6 bar	1.2 kg



Accessories | Brush Grinder - Eraser 4000

Item no.	637084	637085	637086
Item	grinding disk	rubber disk	tool holder for wire brushes
QTY	1 pc.	1 pc.	1 pc.



Wire Brushes | Brush Grinder - Eraser 4000

Item no.	637081	637082	637083
Item	straight Ø 0.5 mm	angled Ø 0.5 mm	angled Ø 0.7 mm
QTY	1 pc.	1 pc.	1 pc.



Accessories | Angle Grinder DG22

Item no.	637089	637087	637088
Item	mounted grinding stone set 10 pc.	back-up pad for cleaning / fleece disks	back-up pad for cleaning / fleece disks
Diameter	shank: 6 mm	51 mm	71 mm
QTY	1 pc.	1 pc.	1 pc.



Cleaning / Fleece Disks

Item no.	Diameter	Fineness	Colour	QTY
637090	51 mm	fine	yellow	1 pc.
637091	51 mm	medium	red	1 pc.
637092	51 mm	rough	green	1 pc.
637093	77 mm	fine	yellow	1 pc.
637094	77 mm	medium	red	1 pc.
637095	77 mm	rough	green	1 pc.







DENT REMOVAL & METALWORKING

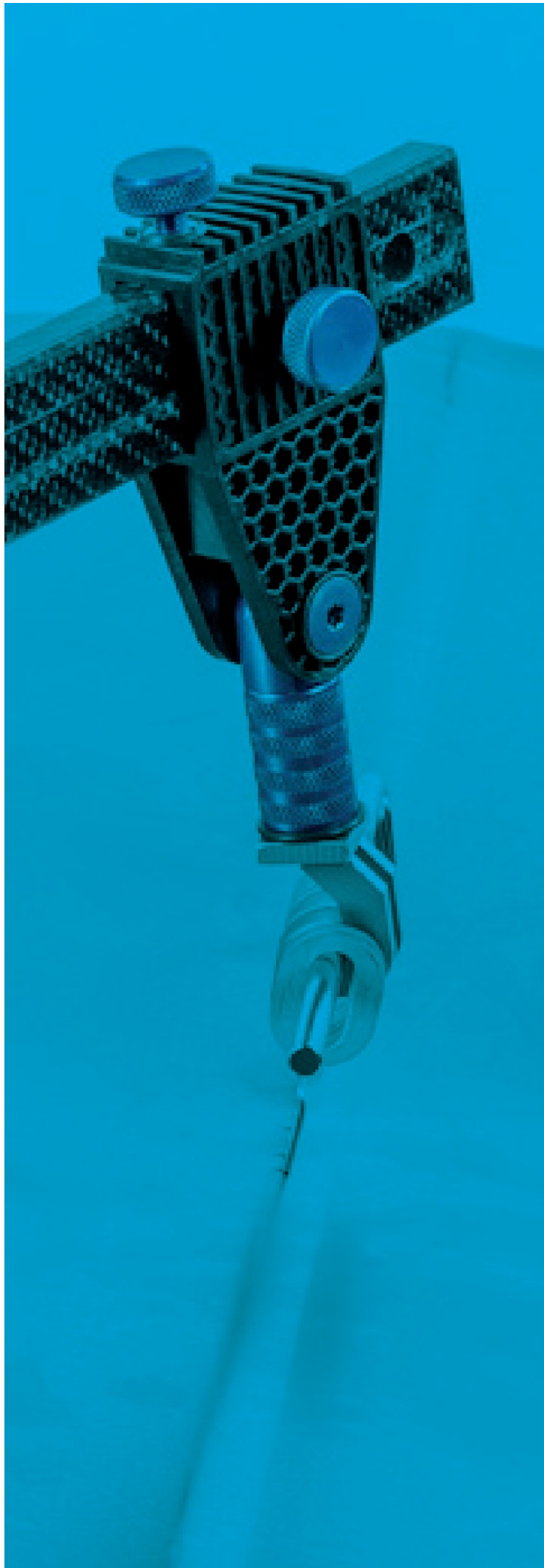

TABLE OF CONTENTS

Trac Tower with vacuum plate	113
Airpuller AP95 & Trafo	114
Work Station WS60	114
Airpuller AP95	116
Work Station WS60	118
Accessories AP95 & Welding Gun PSP	120
CBR Carbon Body Repair System	122
AluRepair Visar	123
AiroPower compressed air press Standard kit	123
AiroPower Eco-Kit 19 pieces	123
CBR gluing technology	124
Clamps	125
Vice Grips	126
Punch and Flange Pliers	127
Crimping pliers	128
Smart Repair	129
Dent removal lamps	130
Auto-Messfix	131
Contour gauges	131
Hammers	132
Body chisel	133
Dollies	133
Body spoons & pry bars	134
Files	134
Wire hand brushes	135
Temporary fasteners	136
Dolly Dent Removal Set WS 93	136
Fix-Cut 1 & Fix-Cut 2	137
Scraper & deburring tools	137
Trim and mounting wedges set	138
CBR 2109 Alluvial tin replacement	139
FlexiTherm Multi-heatpad system	140
2-Component filler alu steel	141
Spatulas, scrapers & brushes	141
Gas burners	142
Tinning	143
Hot air / heating devices	144
Cartridge guns	145
Fix magnets	146
Body Line Marking Tool	147
WS WIPER Tool Kit	147



Mobile dent removal system

The mobile pulling tower with a pulling force of up to 550 kg is held securely on the workshop floor by a pneumatic underpressure plate. The mobile design and the low weight allow a quick change of the position. The traction force can be adjusted in all positions up to a height of 1.65 m, which makes the tower perfect for higher areas such as roof pillars and also lower areas such as door sills.

APPLICATION RANGE:

- ROOF PILLARS
- CAR DOOS
- DOOR SILLS

550 TRAC TOWER WITH VACUUM PLATE



TRAC TOWER 550 with vacuum plate

Item no. 500001

Tractive force	Height adjustment	Max. height (extendible)	Weight
550 kg	15 positions	165 cm (220 cm)	20 kg

Scope of delivery:
 1 x pulling tower cpl.
 1 x vacuum plate
 1 x ratchet with pull strap
 1 x pull hook



Steel Extension 700 mm

Item no. 500002

To increase the pulling tower height up to 2.20 m for the repair of truck and van roofs.

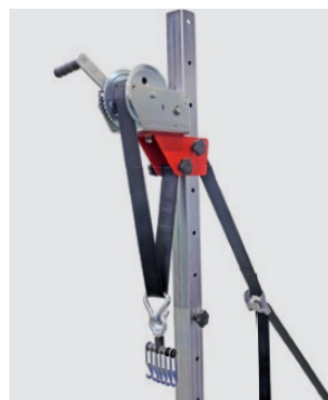
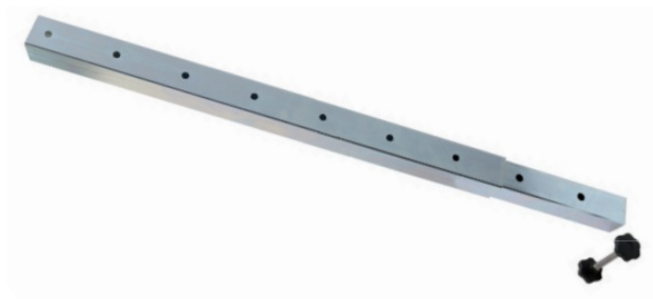

Airpuller AP95 & transformer



VERSATILE

AIRPULLER AP95

With the Airpuller AP95, dent removal work, from the outside, can be carried out in a fraction of the time previously required.

Longitudinal scratches, streaks on the side panels or doors can be easily and quickly repaired with the AP95. The infamous hail damage to car roofs can be repaired without any problems. The Airpuller AP95 can be used immediately and efficiently without any special training.

The Airpuller can be connected to an AP95 transformer, the WS60 transformer or even directly to the spot welder InvertaSpot GT (Item no. 351002).

UNMATCHED IN HANDLING, TIME AND COST SAVINGS

Dent removal work can be performed from the outside in a fraction of the time previously required.

PULLING IN SHEET METAL

ESPECIALLY SUITABLE FOR
HAIL DAMAGE
SMALL DENTS
SCRATCHES & STRIPES
DOUBLE-WALLED SPOTS

HIGH EFFICIENCY

CAN BE IMMEDIATELY USED EVEN WITHOUT TRAINING

SETS AND INDIVIDUAL PARTS ON PAGE 6-7

WELDING GUN INCL. CONTROL LINE

A multifunction gun for many applications.

By changing the contact pieces, it is possible to attach different bits on the car body, matching the dent removal method that follows.

Available options:

- Contact pieces for wiggle wire
- Contact pieces for U-discs
- Contacts for T-pins
- Contacts for bolts
- Contacts for upsetting metal
- Contact pieces for welding bits

The welding gun can be connected to a transformer e.g. WS60 transformer or AP95 transformer.

Mains voltage	Open-circuit voltage	Power max.	Welding current max.
230/400 V 50/60 Hz	7 V	6 kVA	1.1 kA

APPLICATION



COMPLETE DENT REMOVAL STATION FOR CAR BODY REPAIR

The parameters for time and power can be set separately and individually for the repair process.

ANNEALING FUNCTION

WELDING FUNCTION FOR
U-DISCS
STUDS
T-PINS
TRIANGLE WASHERS

EASILY UNDERSTANDABLE DISPLAY

EASY AND SIMPLE OPERATION

SETS AND INDIVIDUAL PARTS ON PAGE 8-9

Mains voltage	Open-circuit voltage	Power max.	Welding current max.
110/400 V 50 Hz	12 V	3 kVA	2.7 kA

Airpuller AP95 & transformer

Item no. 932325

Detailed information on page 112-113

Scope of delivery:

- 1 x transformer
- 1 x Airpuller AP95
- 1 x trolley
- 1 x multi-slide hammer
- 1 x electrode set 5 + 1 pcs.
- 1 x diamond file
- 1 x triangle washers 15 pcs.



Transformer 230/400 V

Item no. 353007

Flexibly adjustable to the local power supply

- 1-phase 220-240 V
- 3-phase 400 V

Note:

The transformer is factory-set for the 400 V three-phase mains.

Scope of delivery:

- 1 x transformer
- 1 x ground cable 4 m
- 1 x ground lug



Airpuller AP95

Item no. 351001

Stepless adjustable pulling height

Note:

Compatible with the spot welder InvertaSpot GT Automatic and the WS60 transformer

Operating pressure	Ø Air connection inside	Sound pressure level	Vibration
6-8 bar	> 4 mm	66 dB(A) DIN45635	< 2.5 m/s ²



Set Airpuller AP95 + transformer

Item no.	Voltage	
352011	230 V	
352012	400 V	



Trolley

Item no. 358030

Transport trolley for the Airpuller AP95 and transformer



Note:

Delivery WITHOUT Airpuller AP95 and transformer



Electrodes for Airpuller AP95

Item no.	357002	357001	357000
Name	Electrode set AP95 steel + copper 6-piece	Copper electrode AP95	Welding electrodes AP95
QTY /	1 pc. /	1 pc. /	5 pcs. /



Diamond file halfround

Item no. 358118

To grind the electrode caps



Multi-slide-hammer

Item no. 351080

The all-rounder!
Enables fast dent removal with the triangular washer and additionally the welding of wiggle wire.

Extendable by further contact pieces for welding of

- U-discs
- T-pins
- bolts



Powerlift + electrode holder for AP95

Item no. 351050

The proven Airpuller AP95 complement for deep and large body dents / dings.

Application:



Electrode holder for Powerlift

Item no. 358060

For mounting 35 mm and 65 mm electrodes to the Powerlift



Electrodes for Powerlift

Item no.	357022	357023
Length	35 mm	65 mm
QTY /	4 pcs. /	3 pcs. /



Work Station WS60

Item no. 352060

Detailed information on page 112-113

Scope of delivery:

- 1 x transformer WS60
- 1 x trolley
- 1 x Welding gun PSP
- 1 x Dent pulling hammer
- 1 x Assortment box*

* For details, see Item no.: 358000



Welding gun PSP60 inkl. control line

Item no. 351070

Gun for welding pins, bolts, washers & wiggle wire.
Also for upsetting sheet metal and working with carbon electrodes.

Note:

Also compatible with the AP95 transformer.



Dent pulling hammer | 1.1 kg

Item no. 358037



Trolley AP95

Item no. 352062

Trolley for the WS60 workstation



Assortment box

Item no. 358000

Scope of delivery:

- 1 x contact pc. for studs 5 / 6 mm
- 1 x contact pc. for T-pins
- 1 x contact pc. for u-discs
- 1 x copper electrode
- 1 x triangle washers (20 pcs.)
- 1 x U-discs (50 pcs.)
- 1 x studs M5 x 18 (50 pcs.)
- 1 x studs SelfLock 5 x 19 mm (50 pcs.)
- 1 x studs SelfLock 5 x 13 mm (50 pcs.)
- 1 x T-pins 3 x 3.2 mm (50 pcs.)
- 1 x T-pins 3 x 4.5 mm (50 pcs.)
- 1 x allen key



Contact pieces for welding gun PSP

Item no.	497014	497015	497019	497021	497023	497017	507034
Application	Wiggle wire	U-discs	T-pins	Studs 2-2.5 + 4 mm	Studs 5 + 6 mm	Upsetting metal	Weld-on bits Line Puller
QTY /	1 pc. /	1 pc. /	1 pc. /	1 pc. /	1 pc. /	1 pc. /	1 pc. /



Carbon electrode for welding gun PSP

Item no. 297107

Diameter: 9.5 mm
Length: 305 mm



Quickpull-slide-hammer | Set

Item no. 501040

Note:

Only suitable for spot welding gun InvertaSpot ATM/ATL

Scope of delivery:

- 1 x Slide-hammer
- 1 x Contact piece for triangular washers
- 5 x triangular washers



Quickpull-slide-hammer | Set

Item no. 478100

Note:

Only suitable for the InvertaSpot GT and the welding gun PSP60 (351070)

Scope of delivery:

- 1 x Quickpull-slide-hammer GT (M14)
- 1 x Contact piece for triangular washers (M14)
- 1 x Hook for U-discs
- 1 x U-discs (100 pcs.)
- 5 x triangular washers



Quickpull-slide-hammer M14

Item no. 501025

Note:

Only suitable for the InvertaSpot GT and the welding gun PSP60 (351070)

Scope of delivery:

- 1 x Quickpull-slide-hammer GT



Contact piece for triangular washers

Item no.	501031	501033
Thread	M10	M14
QTY /	1 pc. /	1 pc. /



Hook for U-discs

Item no.	501034
Thread	M14
QTY /	1 pc. /



Consumables | for steel

Item no.	297013	297009	497028	821010	821011
Name	Triangular washers	U-discs DIN 125	U-discs copper plated	Line Puller Steel Welding Bits straight	Line Puller Steel Welding Bits twisted
QTY	15 pcs.	100 pcs.	100 pcs.	800 g (+/- 110 pcs.)	800 g (+/- 110 pcs.)



Line Puller 1250 | Set

Item no. 821102

The Line-Puller which has a length of 1250 mm is designed to be used on areas and edges with extensive damages over long distances. Despite its length the Line-Puller can be operated by one person without any problems. Due to the integrated range spring, the height of the damaged sheet metal, or the edge, can be reliably measured with a non damaged part of the vehicle.

Scope of delivery:

- 1 x aluminum bar 1250 mm with straight feet
- 1 x pulling device with 2 hooks
- 1 x pulling device with 3 hoods
- 1 x pulling rod set 4 pieces | Ø 8 mm
- 2 x suction cup holders
- 1 x measuring spring bar



Wiggle wire

Item no.	507030	507031
QTY	10 pcs.	50 pcs.

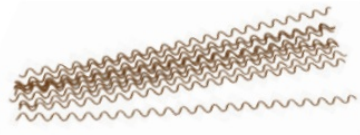

Wiggle wire accessories

Item no.	507035	507040	561190
Name	Wiggle wire welding electrode	Wiggle wire magnetic holder	Vice Grip for Wiggle Wire
QTY	1 pc.	1 pc.	1 pc.



Maxilift + 3-finger claw

Item no. 351060

For quick dent removal of bodywork damage with the aid of the leverage effect.



Accessories Maxilift / Powerlift

Item no.	354105	354110	358050	358200
Name	Rubber plate	Handle	3-finger claw	Magnetic Clamp
QTY	1 pc.	1 pc.	1 pc.	1 pc.

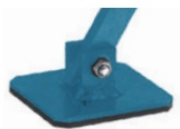

WS Handpuller Set

Item no. 351010

For small and medium body repair work.



Welding electrode for WS Handpuller

Item no. 354055



Dent pulling hammer + Bi-puller + Coupling

Item no. 502002

Perfect set for pulling and straightening by using wiggle wire



Accessories

Item no.	501005	504011	504012	508021	501009
Name	Pulling hammer 4 kg with round hook	Round hook	Long nut	Coupling Bi-Puller	Bi-Puller 9-finger claw
QTY	1 pc.	1 pc.	1 pc.	1 pc.	1 pc.



Pulling hammer with round hook

Hook

Item no.	511300	511301	511310
Weight	5 kg	9 kg	extra strong



Transformer accessories

Item no.	358410	358411	358400	354400
Name	Ground cable 2 m Dinse DIX SK 35	Ground extension cable 2 m	Magnetic chassis ground MC95	Contact sleeve for magnetic chassis ground MC 95
QTY	1 pc.	1 pc.	1 pc.	1 pc.



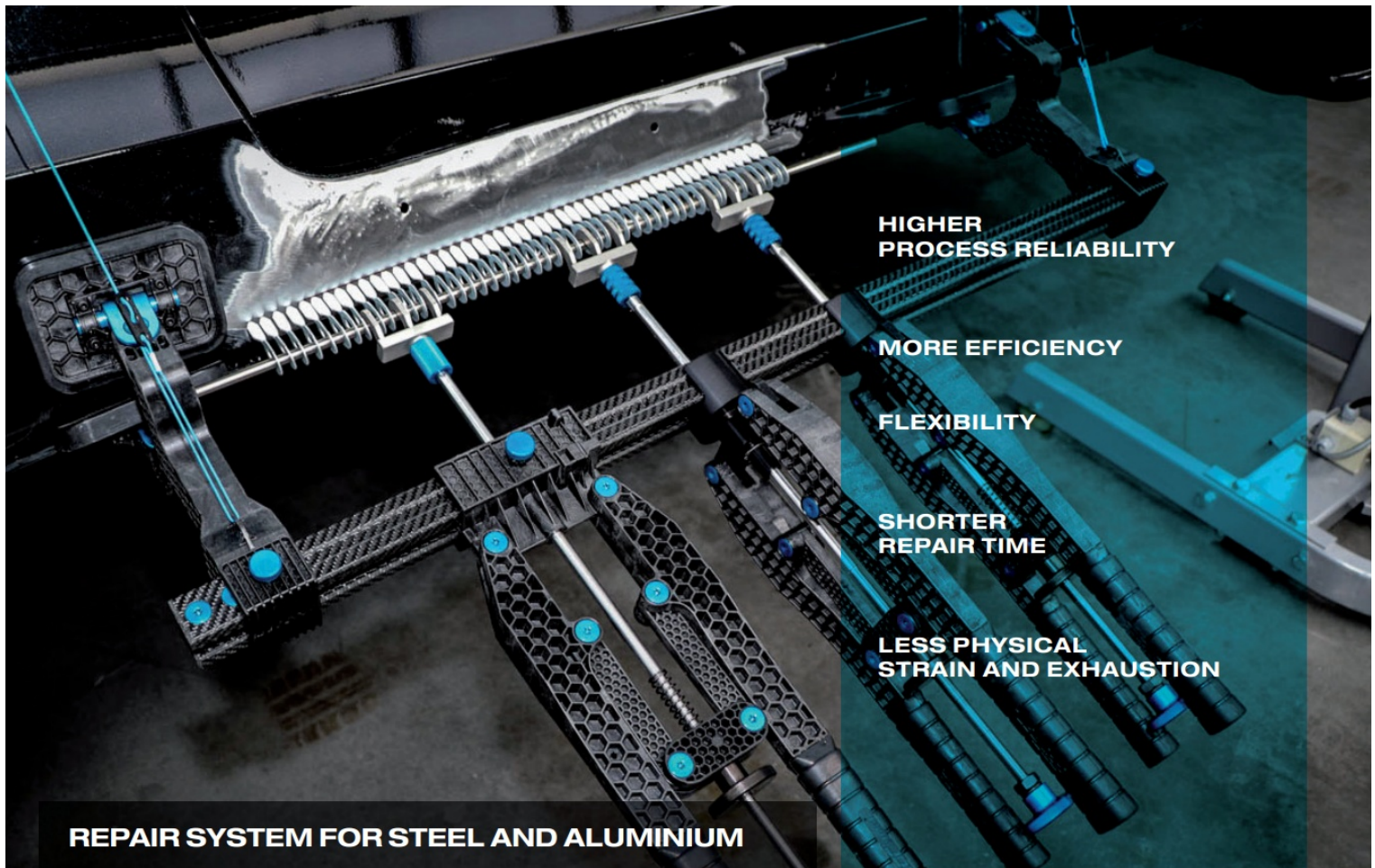

**HIGHER
PROCESS RELIABILITY**

MORE EFFICIENCY

FLEXIBILITY

**SHORTER
REPAIR TIME**

**LESS PHYSICAL
STRAIN AND EXHAUSTION**

REPAIR SYSTEM FOR STEEL AND ALUMINIUM

The extremely low weight of the CBR pulling components considerably reduces the effort required for everyday straightening work. A panel beater can easily work alone with the Strong- or Line-Tool. Compared to other systems, the application of the pulling tools – especially when working overhead – is radically easier and absolutely fatigue-free.

CBR

CARBON BODY REPAIR SYSTEM

Carbon Body Repair System CBR

Item no. 821522

Scope of delivery:

CBR-029	System wagon
CBR-C1	Welding inverter(CE)
CBR-ST-00	Strong-Tool
CBR-ET-00	Easy-Tool
CBR-LT-00	Line-Tool 160
CBR-LV-00	Lever-Tool
CBR-ZH-01	Pullhammer S
CBR-ZH-02	Pullhammer M
H01-HG	Bumping hammer small (330 g) Rubber cap
H03-H	Bumping hammer large (555 g/horizontal)
H03-V	Bumping hammer large (555 g/vertical)
CM-023	Paint removal kit (incl. special flex. backing pad)
CM-024	Bit-Cutter (incl. Retrofit kit; M-02;MB-02; MB-3; MB-4; MB-5)
CM-060	Small accessories set
CM-025	Pulling rods 7 mm
CM-026	Pulling rods 8 mm
CBR-00	User manual



AluRepair Visar

Item no. 821506

With the proven, absolutely process-safe drawn arc method with up to 1,200 A welding current and the patented welding gun, various types of studs can be welded on a wide range of steel and aluminum alloys.

Scope of delivery:

CMA-1200	Power unit CMA-1200 for drawn arc stud welding Welding gun with bit holder, hose package, gas hose
CMA-142	System cart
CMA-160	Pressure regulator
CMA-252	Gas hose
CMA-150	Pyrometer
CMA-137	Alu-Bits-Set (14 types á 50 pieces)
CMA-170	Stud chuck 4 mm
CMA-171	Stud chuck 5 mm
CMA-172	Stud chuck 6 mm
CMA-175	Stud chuck 8 mm
CMA-176	Stud chuck 10 mm
CMA-177	Gas tube 42 mm for studs 4 / 5 / 6 mm
CMA-175-1	Gas tube 48 mm for studs 8 mm
CMA-176-1	Gas tube 58 mm for studs 10 mm
CMA-178	Stud chuck 4 mm for extractor studs
CMA-179	Stud chuck 5 mm for extractor studs
CMA-181	Stud chuck 6 mm for extractor studs
CMA-178-1	Gas tube 110 mm for extractor studs
CMA-155	Pincers for Alu-bits
CMA-120	Pull-hook for Easy-Puller
CMA-130	Temperature indicator stick
MS-U-B16	Shrinking tip aluminium (12 x 72 mm)
MS-U-B17	Shrinking tip aluminium (12 x 72 mm)



AiroPower pneumatic press | Standard-Kit

Item no. 821150

The AiroPower is a universal tool for every body professional. In combination with the Miracle system, the press exploits its full potential.

Scope of delivery:

1 x	AiroPower pneumatic press
1 x	19205P Male connector
2 x	19206P Female connector
1 x	19207P Rubber flex head
1 x	19208P Serrated saddle
1 x	19209P Flat base
1 x	19210P Collar toe
1 x	19211P Plunger toe
1 x	19212P V-Base
1 x	19213P Wedge head
2 x	19214P-V Pull hook
1 x	19216PS Connector kit
1 x	19217P Stopper pin
1 x	19260P Extension tube 125 mm
1 x	19261P Extension tube 170 mm
1 x	19262P Extension tube 300 mm
1 x	19263P Extension tube 500 mm
1 x	19245P-V Product case



AiroPower Economy-Kit | 19 pieces

Item no. 821106

Scope of delivery:

2 x	19220P Adjustable body spoon
1 x	19234 P AiroPower clamp
1 x	19235P Multi clamp
2 x	19236P AiroPower clamp, wide
2 x	19237P Grooved foot
1 x	19260P Extension tube 125 mm
1 x	19261P Extension tube 170 mm
1 x	19262P Extension tube 300 mm
1 x	19263P Extension tube 500 mm
1 x	19273P Connecting plate
2 x	19274P Single adapter
2 x	19275P Double adapter
1 x	19277P Propeller
1 x	30310 Metal case L (Longbox)

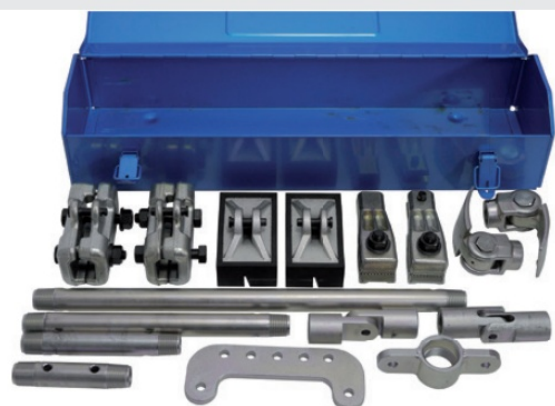

CBR Gluing technology

Round deformations without body edges are pulled flat by the large-area connection of the gluing pads with the panel metal. Thus this you can pull out the material softer and gentler. The gluing technique is ideal for damage to sills, side panels, hoods or the rear part. Up to 80% of the deformation can thus be formed back in an extremely short time.

The gluing technology perfectly complements the already existing tensile components and the AiroPower pneumatic press. The glue set is usually amortized as a result of the high time savings in the repair of the first damage.

Miracle GlueTech Plus | Gluing Kit MGT-400

Item no. 821395



Scope of delivery:

- 1 x MGT-401 Case to Miracle GlueTech Plus
- 2 x CGP-902 Special glue
- 1 x CKS-302 Special cleaner (250 ml)
- 1 x CKS-303 Gluing gun Gluematic
- 3 x MGT-200 GlueTech Plus gluing pads set | blue
- 1 x MGT-10 GlueTech Plus connecting plate
- 3 x MGT-11 GlueTech Plus pull strip | blue

Miracle Gluing Kit | MKS-100

Item no. 821101



Scope of delivery:

- 1 x CKS-304 Case
- 2 x CGP-902 Special glue
- 1 x CKS-302 Cleaner (250 ml)
- 1 x CKS-303 Glue gun Gluematic
- 2 x B-200 Gluing pads set blue / medium
- 1 x S-300 Gluing pads set black / hard
- 1 x CZ-122b Plastic wedge for the removal of glued pads



Clamps

Item no.	511311	511312	511314	511315	511319
Name	Angle clamp 90°	Mity-Bite clamp large	Mini-Byte clamp small	Double-sided clamp	Mity-Bite clamp with ring loop
QTY	1 pc.	1 pc.	1 pc.	1 pc.	1 pc.



Pulling clamps | self-locking

Item no.	511420	511421	511424
Name	Pulling clamp K210 small self-locking	Pulling clamp K211 large self-locking	Pulling clamp K214 lateral self-locking
QTY	1 pc.	1 pc.	1 pc.



Item no.	511317	511325	511429	501310
Name	Chain shortener	Claw hook	Holder for Hook and Clamp	Nylon pulling belt 1200 x 80 mm
QTY	1 pc.	1 pc.	1 pc.	1 pc.



Spare parts for Mity-Bite clamp

Item no.	514001	514003	514004	514005
Name	Cone	Screw set	Wing nut	Spare jaws incl. screws
QTY	1 pc.	1 pc.	1 pc.	1 pc.

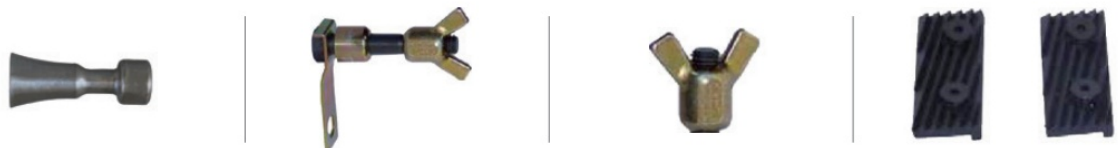

Vice Grips

Item no.	561151	561152	561153
Name	Vice Grip 145 U-shape	Vice Grip 144	Vice Grip 224 with swivel pads
QTY	1 pc.	1 pc.	1 pc.



Vice Grips

Item no.	561150	561154	561157
Name	Vice Grip 112 straight jaws 5"	Vice Grip 111 curved jaws 10"	Vice Grip long jaws - 81 mm
QTY	1 pc.	1 pc.	1 pc.



BESTSELLER



Vice Grips axial

Item no.	561181	561182	561183
Name	Vice Grip Axial DW	Vice Grip Axial DS	Vice Grip Axial D
QTY	1 pc.	1 pc.	1 pc.



Item no.	561184	561185	561186
Name	Vice Grip Axial T	Vice Grip Axial WS	Micro Grip 2000 Length: 90 mm
QTY	1 pc.	1 pc.	1 pc.



BESTSELLER

Vice Grips spezial

Item no.	561190	561191	561230
Name	Vice Grip for wiggle wire	ErgoGrip	Clamping pliers N°2 - 300 mm
QTY	1 pc.	1 pc.	1 pc.



BESTSELLER

Punch and Flange Pliers			
Item no.	561001	561005	561002
Name	Punch and Flange Pliers mechanical Ø 5 mm	Flange Pliers flat shape	Punching hand pliers 6 x 20 mm longitudinal holes
QTY	1 pc.	1 pc.	1 pc.

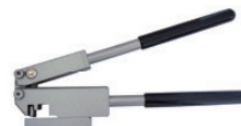

Punch and Flange Pliers			
Item no.	561021	561022	561023
Name	Hole punching pliers mechanical Ø 5 mm	Hole punching pliers mechanical Ø 6 mm	Flange pliers mechanical for rounded areas
QTY	1 pc.	1 pc.	1 pc.



BESTSELLER



Spare parts			
Item no.	Name		
564008	Punch Ø 6 mm for mechanical punching pliers		
564009	Die Ø 5 mm for mechanical punching pliers		
564010	Die Ø 6 mm for mechanical punching pliers		
564011	Bearing-bolt with washer for mechanical pliers		
564013	Allen screw M 3 x 3 for mech. punching pliers		
564016	Distance-collar Ø 5/6 mm for mech. punching pliers		

Punch and Flange Pliers pneumatic			
Item no.	561090	561091	
Name	Hole punching pliers pneumatic Ø 5 mm	Hole punching pliers pneumatic Ø 6 mm	
QTY	1 pc.	1 pc.	



Spare parts			
Item no.	Name		
564001	Piston for pneum. punching pliers		
564003	Head Ø 6 mm for pneum. punching pliers		

Chain pipe cutter	
Item no.	561025

Chain pipe cutter for pipes with a diameter of 15 - 75 mm.
 For cutting pipes, especially V2A steel up to 2.5 mm wall thickness. During cutting, you can easily adjust the pliers with the wing screw.



Crimping pliers set | 3-piece

Item no. 561020

Sturdy professional design with ergonomic handles

- For finishing and flanging of wheel arches
- For flanging of edges on door panels
- Perfect radius at the bending edge

Scope of delivery:

- 1 x Crimping pliers size 1 | shape narrow & short | Item no. 561015
- 1 x Crimping pliers size 2 | shape wide & short | Item no. 561016
- 1 x Crimping pliers size 3 | shape wide & long | Item no. 561017



Crimping pliers set | 5-piece

Item no. 561010

For sheets up to 1.5 mm

- For finishing and flanging of wheel arches
- For flanging of edges on door panels
- For opening the seams on door panels, etc.
- Perfect radius at the bending edge

Scope of delivery:

- 1 x Crimping pliers size 1 | shape narrow & short | Item no. 561015
- 1 x Crimping pliers size 2 | shape wide & short | Item no. 561016
- 1 x Crimping pliers size 3 | shape wide & long | Item no. 561017
- 1 x Crimping pliers size 4 | 90° angled shape | Item no. 561018
- 1 x Seam opening pliers size 5 | Item no. 561019

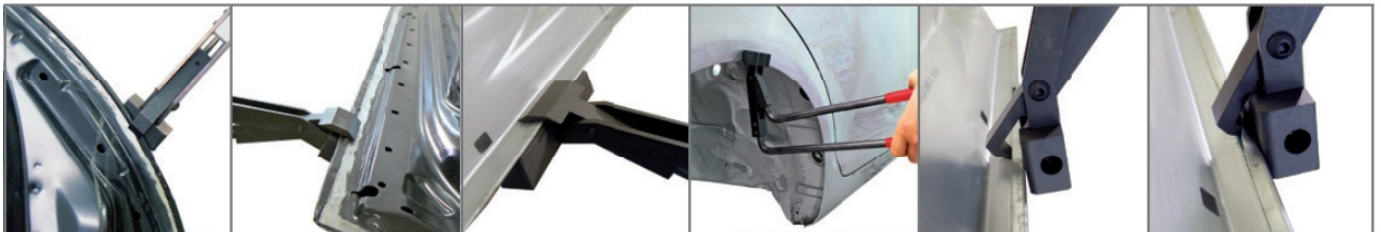

Crimping pliers

Item no.	561015	561016	561017
Name	size 1 narrow & short	size 2 wide & short	size 3 wide & long
QTY	1 pc.	1 pc.	1 pc.



Item no.	561018	561019	561014
Name	size 4 90° angled	size 5 seam opening pliers	size 6 wide & short with gap
QTY	1 pc.	1 pc.	1 pc.



INITIAL USE: **PORSCHE PANAMERA**

Plastic Repair Kit

Item no. 391300

For the professional repair of typical plastic damage on bumpers, fenders, etc.

Hot air gun:

- Electronically controlled, digital temperature setting from 80 - 650 °C.
- Temperature displayed in 10 °C increments via LCD display
- Air volume regulation in 2 steps from 150 - 500 l/min
- Residual heat indicator
- Warning in case of heat accumulation
- Optimized center of gravity
- Non-slip base
- Option to store in hanging position
- Replaceable power cord

Scope of delivery:

- 1 × Hot air gun
- 1 × Reduction nozzle 9 mm
- 1 × Welding nozzle
- 10 × Multi-Thermoflex - plastic welding rods
- 5 × Stainless steel wire mesh
- 1 × Heat protection disk



Accessories

Item no.	394010	394012	394014
Name	Welding nozzle	Heat protection disc	Reduction nozzle 9 mm
QTY	1 pc.	1 pc.	1 pc.

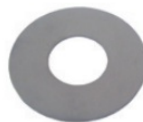

Consumables

Item no.	397010	397015	397016
Name	Multi-Thermoflex - plastic welding rods	Stainless steel wire mesh 110 × 150 mm	Stainless steel wire mesh 300 × 200 mm
QTY	20 pcs.	10 pcs.	3 pcs.

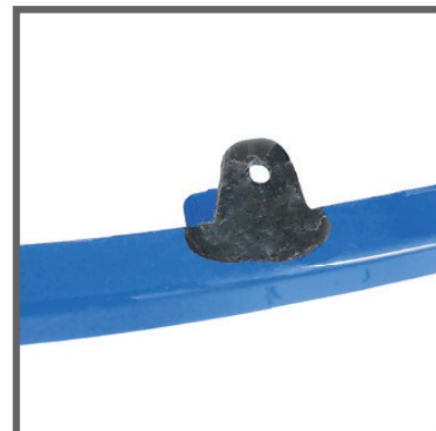
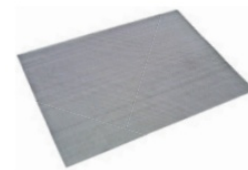
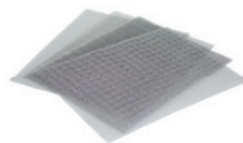



Dent removal lamps

Item no.	388040	388042
Variant	with magnetic base	with suction cup



X-Light | 3 in 1

Item no. 881309

Rechargeable 3-in-1 Li-Ion inspection lamp with easy quick connect to change lamp heads.

- Flashlight with focus and a magnetic base
- Work light 180° forward and backward tilting
- Inspection lamp bendable with focus - length 400 mm
- Foam insert for workshop trolley
- Charging time Li-Ion battery 3-4 hours



	Flashlight	Swivel working light	Flexible inspection light
LEDs	CREE	COB	CREE
Color temperature	5800-6500 K	5800-6500 K	5800-6500 K
Brightness	100 % = 280 lm 50 % = 140 lm	100 % = 350 lm 50 % = 175 lm	100 % = 200 lm 50 % = 100 lm
Beam distance	100 % = 150 m 50 % = 35 m	100 % = 24 m 50 % = 16 m	100 % = 24 m 50 % = 10 m
Operating time	100 % = 2.5 h 50 % = 5.5 h	100 % = 2.5 h 50 % = 5 h	100 % = 5.5 h 50 % = 8 h

SMD - LED workshop lamp

Item no. 881307

The SMD features impressive 350 lumens, 180° light width and a rechargeable Li-Ion battery with 2100 mAh without memory effect for long service life.

- SMD LED sidelight and powerful LED main light
- Two suspension hooks for work from different angles
- Flexible folding mechanism (can be tilted 180 degrees)
- Two built-in powerful magnets for two different mounting positions (horizontal and vertical)
- Over- and discharge protection system (automatic shut-off mechanism)



LED hood light | 115-180 cm

Item no. 881312

Rechargeable aluminum hood light with Li-Ion battery.

- Extremely thin
- Extremely bright light
- Glare-free
- Wide light spectrum of 120°
- Adjustable aluminum holder 115 ~ 180 cm
- 360° Rotatable, soft, padded hook ends



LEDs	Color temperature	Brightness	Battery	Charging time	Operating time	Charger	Shock resistance
62 SMD 7 W	5650 ~ 6500 K	100 % = 1000 lm	3.7 V DC 4.4 Ah Li-Ion	5 h	100 % = 3 h	Micro USB 1 A 5 V	IK08

Cree Pen Light 4000 - LED Flashlight

Item no. 881308

- Shock resistant (approx. 1 m drop height)
- Splash-proof (IP65)
- 160 lumens
- 50 m range
- 24 h operating time



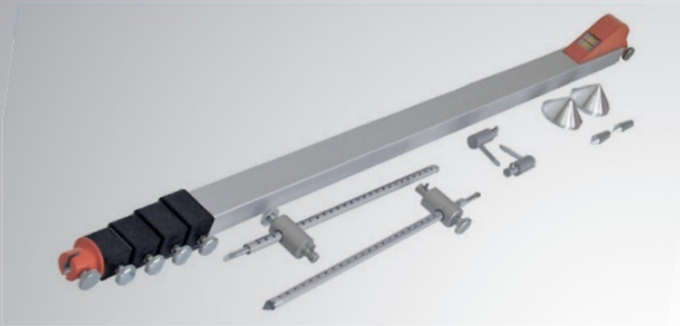

FAST

RELIABLE

ACCURATE

Measuring technology for car body repair

Ideal for assessing damage, measuring structural damage or checking dimensions after body repair. Simply extend the telescopic tubes and conveniently read the distance between two body measuring points on the analog display of the AUTO-Messfix.

**AUTO-MESSFIX
TELESCOPIC DIPSTICK**

AUTO-MESSFIX

Item no.	871001	871002	871004	871006
Length	920-2610 mm	415-925 mm	950-3260 mm	990-4000 mm
VE	1 pc.	1 pc.	1 pc.	1 pc.

AUTO-MESSFIX accessories

Item no.	871008	874020	874021	874024	874026	874027
Length	Measuring cone	Measuring tip straight	Measuring tip angled	Locking screw	Measuring tube 20-280 mm	Holder for measuring tube
VE	1 pc.	1 pc.	1 pc.	1 pc.	1 pc.	1 pc.



Profile template contour gauge | 1 m (5 x 20 cm)

Item no. 861020

The template - standard length 200 mm - is a profile scanner which can theoretically be assembled and extended indefinitely. This results in increased accuracy and enormous time savings when transferring contours. Due to the flat and even contact of the template, the profile line can be easily traced over onto the workpiece which is to be adapted. The stencil can be adjusted in all directions by means of the enclosed setting angle. The scanned profile can be secured and transported in the case.



Item no.	871011	861001
Name	Gap gauges 3 pcs.	Contour gauge plastic 250 mm
VPE	1 pc.	1 pc.



Aluminium hammer set | 4-piece

Item no. 512002

Aluminum hammers in four different sizes **for car body repair.**



Hammers

Item no.	511020	511021	511025	511026
Name	Bumping hammer 300 g	Bumping hammer 400 g	Goldsmith hammer	Finishing and grooving hammer
QTY	1 pc.	1 pc.	1 pc.	1 pc.
				<p>BESTSELLER</p>

Hammers

Item no.	511027	511023	511028	511029
Name	Wooden mallet N°3 500 g	Wooden mallet N°2 350 g	Plastic hammer recoilless	Soft-face hammer recoilless
QTY	1 pc.	1 pc.	1 pc.	1 pc.
<p>BESTSELLER</p>				

Hammers

Item no.	511030	511031	511032	511033
Name	Aluminium hammer	Hammer elastonal recoilless	Dolly hammer 3 areas	Dolly and planishing hammer
QTY	1 pc.	1 pc.	1 pc.	1 pc.
<p>BESTSELLER</p>				

Hammers

Item no.	511035	511034	511039	511040
Name	Dolly hammer twist head	Hammer with nylon heads	Planishing hammer	Locksmith's hammer 300 g
QTY	1 pc.	1 pc.	1 pc.	1 pc.
<p>BESTSELLER</p>				

Item no.	512001	511002	518001
Name	Body chisel incl. handle	Body chisel	Body chisel handle
QTY	1 pc.	1 pc.	1 pc.



Dollies				
Item no.	511100	511102	511103	511105
Name	Wedge shape - roof dolly 1150 g	Wedge shape 900 g	Hatchet shape 1600 g	Flat shape 950 g
Dimensions	Length = 130 mm	112 x 64 mm	192 x 45 x 77 mm	106 x 60 x 25 mm
QTY	1 pc.	1 pc.	1 pc.	1 pc.



Dollies				
Item no.	511110	511111	511112	511113
Name	Toe shape 1200 g	Toe shape Cross-milled face 1100 g	General purpose dolly 1100 g	Heel shape 1050 g
Dimensions	115 x 60 x 28 mm	125 x 55 x 25 mm	75 x 55 x 57 mm 60 x 45 x 57 mm	80 x 60 x 35 mm
QTY	1 pc.	1 pc.	1 pc.	1 pc.



BESTSELLER



Dollies				
Item no.	511114	511117	511119	
Name	Diabolo shape 850 g	Daimler shape 1500 g	WS P universal 760 g	
Dimensions	Ø 60 x 55 mm	105 x 50 x 50 mm	120 x 56 x 21 mm	
QTY	1 pc.	1 pc.	1 pc.	



Body spoons & pry bars

Item no.	511220	511221	521102
Name	Body spoon heavy curved	Body spoon with cambered, almost flat working surface	Body spoon K with bush-hammered, rectangular work surface and plastic handle
Dimensions	150 x 50 mm	200 x 60 x 30 mm	350 x 36 x 36
QTY	1 pc.	1 pc.	1 pc.



Item no.	511202	511204	511206
Name	Pry bar	Pry bar with rolling head nickel-plated	Pry bar 400 - general purpose nickel-plated
QTY	1 pc.	1 pc.	1 pc.



Item no.	561030	531100	531101
Name	Nipper pliers heavy duty	Snips 260 mm left	Snips 260 mm right
QTY	1 pc.	1 pc.	1 pc.



Item no.	523222	521201	521203
Name	File Set 6-pieces	File incl. handle medium cut 1	File incl. handle fine cut 3
QTY	1 pc.	1 pc.	1 pc.



Files

Item no.	521210	521231	521240	521230
Name	Bodywork file holder	Wooden body file straight	File holder 350 mm	Wooden body file half-round
QTY	1 pc.	1 pc.	1 pc.	1 pc.

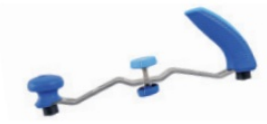

File blades for 521210, 521231 & 521240

Item no.	521211	521212	521213	521214
Name	File blade diagonal cut Z2 - medium	File blade radial cut Z1 - coarse	File blade radial cut Z2 - medium	File blade radial cut Z3 - fine
QTY	1 pc.	1 pc.	1 pc.	1 pc.



for 521230

521225
File blade half-round
1 pc.



Wire hand brush

Item no.	541211	541212
Material	stainless steel	stainless steel
QTY	1 pc.	1 pc.



Temporary fasteners

Item no.	577108	577104	577109	577106	577107	577110
Ø	2.5 mm	4.1 mm	4.7 mm	6.0 mm	6.35 mm	8.0 mm
QTY	20 pcs.	20 pcs.	20 pcs.	30 pcs.	20 pcs.	20 pcs.



Dolly WS 93 - Dent Removal Set

Item no. 582001

1 Powerful dent removal block:

For dent removal in extreme places and curves, even strong sheet metal. Ideal for straightening profiles on fenders and side panels as well as front and rear panels.

2 Handy and light conical bar:

Effortless removal of beads and edges, straightening of dents. Can also be used as a powerful lever.

3 Universal cube:

The uni cube surprises with its shape. By using the groove, seams and profiles can be straightened laterally and also in height. It is also an important fitting aid for hoods and trunk lids.

4 Special profile wedge:

The design gives the profile wedge variable application possibilities. Due to the 90° impact edge, steel sheets are precisely straightened. In addition, clean and damage-free work on various body parts. Can also be used for precision work in particular.

Scope of delivery:

- 1 x Powerful dent removal block
- 1 x Handy and light conical bar
- 1 x Universal cube
- 1 x Special profile wedge

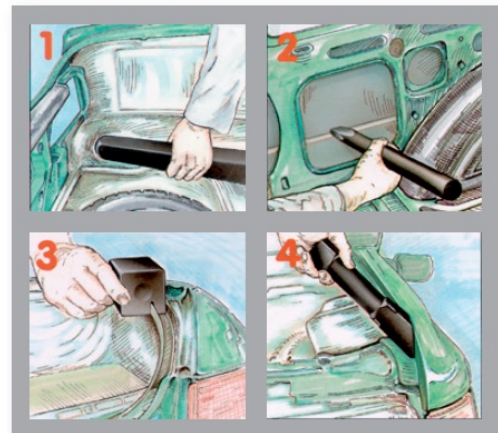

Item no.	581001	581002	581003	581004
Name	Powerful dent removal block	Handy and light conical bar	Universal cube	Special profile wedge
QTY	1 pc.	1 pc.	1 pc.	1 pc.



Clip pliers

Item no. 561029

For the removal of clips from door panels. Remove clips without damaging the delicate door panels. In many cases, the clips can be reused.



Fix-Cut 1 - Scraper blades set

Item no. 547032

- Professional scraper blades
- Compact handle excellently transmits the force
- Convex back - for removing PU adhesive according to instructions
- Rounded side wings of the blades
- Perfect individual tuning of blade sharpness
- The correct adhesive thickness is retained for re-gluing

Scope of delivery:

- 2x 20 mm scraper (547033)
- 2x 25 mm scraper (547034)
- 2x Handle
- 1x Grinding stone
- 1x Allen key
- 1x Transport case

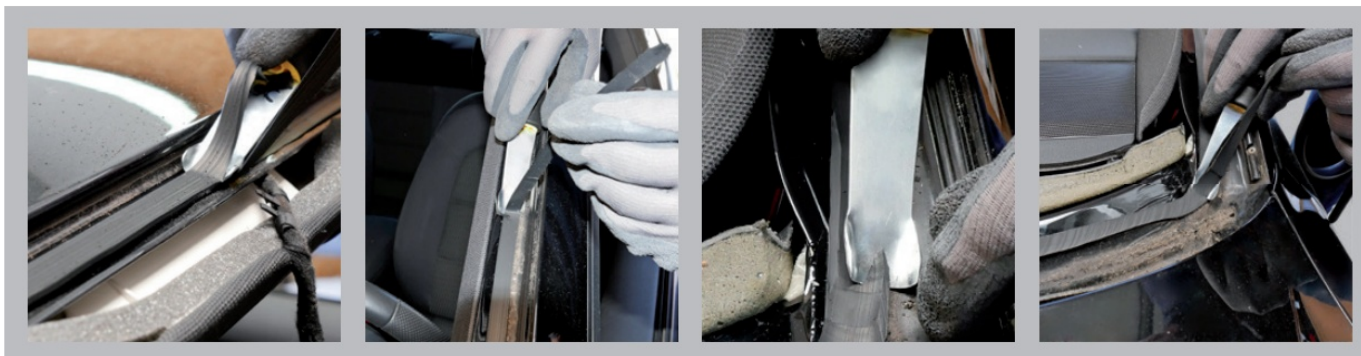

Fix-Cut 2 - Contour blades set for general purposes

Item no. 584036

The universal contour blade set is suitable for removing PU adhesives, glues and sealants under the most demanding conditions.

The contour blades are made of knife steel and are extremely sharp. Special comfort is provided by the compact handle with finger protection pad.

Blades with applications for left and right side.

Scope of delivery:

- 1x Handle
- 1x Scraper straight, 40 mm
- 1x Scraper right 20 mm
- 1x Scraper left 20 mm
- 1x Scraper right 16 mm
- 1x Scraper left 16 mm
- 1x Scraper straight 16 mm
- 1x Scraper straight 20 mm
- 1x Blade straight 12 mm
- 1x Grinding stone
- 1x Transport case



Item no.	932700	541001	541005	541030
Name	TFO 100 door rebate remover	Hard metal scraper 3-edges 24 mm	Hard metal scraper 50 mm	Deburring tool
QTY	1 pc.	1 pc.	1 pc.	1 pc.



Item no.	932702	547001	547005	547030
Name	Spare blades TFO 100	Spare blade 3-edges	Spare blade 50 mm	Spare blade deburring tool
QTY	5 pcs.	1 pc.	1 pc.	1 pc.



Trim and mounting wedges set

Item no. 581100

Simple and quick removal of decorative strips and removal of shaft strips on windows and doors. Also a practical lever for fitting doors and adjusting painted sheet metal parts. Paint, plastic and metal parts do not get damaged. Quick removal of door panels, plugs and clip connections. For removing the buttons on heaters, radio etc., as well as for removing the interior mirrors. Made of impact-resistant special plastic.

Scope of delivery:

- 1 x Trim wedge - white
- 1 x Trim wedge - extra wide
- 1 x Trim wedge - white, with felt overlay
- 1 x Mounting wedge - gray
- 1 x Trim wedge - black



Item no.	581101	581102	581103	581104	581105	581106
Name	Trim wedge white	Trim wedge extra large	Trim wedge white with felt	Trim wedge grey	Trim wedge black	Trim wedge laterally wedge-shaped
QTY	1 pc.			1 pc.	1 pc.	1 pc.

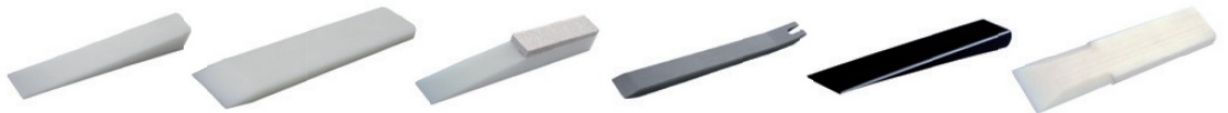

Scraper and mounting wedges

Item no. 581110

Removal from:

- Rear view mirrors
- Balance weights of alloy rims
- door panels
- closing plugs
- upholstery

The mounting wedges made of fiberglass allow easy removal without protective means. There is no risk of damage to the sensitive parts.

Scope of delivery:

4-piece Set



CBR 2109 | Alluvial tin replacement

Item no. 542040

CBR 2109 is a unique 2-component epoxy-based solder substitute used to restore metal surfaces of steel or aluminium. Formulated for final modelling of repulled dents or weld seams.

Properties:

- Good adhesion to aluminum, steel and zinc
- easy processing (sanding, planing)
- ideal base system for paint
- easy to mold
- great stability
- fast curing
- no collapsing or running

Scope of delivery:

1 x CBR 2109 cartridge 200 ml

3 x CBR 2109 mixing tubes

Recommended applications:

- Car body repairs
- Gap filling material
- Metal bonding
- Carrier system for auto-motive paints



Mixing tubes CBR 2109

Item no. 542042

Scope of delivery:

10 x CBR 2109 mixing tubes

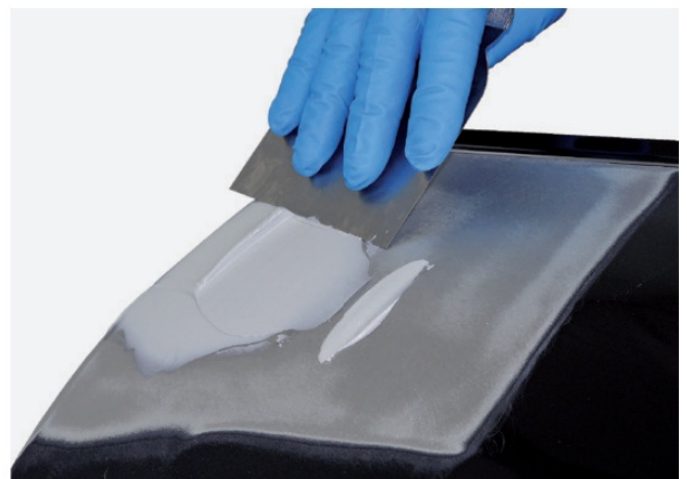



- PROCESS RELIABILITY
- 100 % CONTROL
- TIME SAVING
- ENERGY SAVING
- MOBILE AND SPACE SAVING
- EASY OPERATION
- HEALTH-FRIENDLY

Drying process exactly according to manufacturer's specifications

The innovation for process-reliable curing of body adhesives, fillers and automotive windshield adhesives. Work on the vehicle body can continue during the drying process.

MULTI-HEATPAD-SYSTEM FlexiTherm

FlexiTherm Multi-Heatpad-System

Item no. 701000

Mains voltage	Input power	Power	Frequency	Temperature range
100-240 V	360 VA max.	25 V/110 W (je Heizpad)	50/60 Hz	20-100 °C

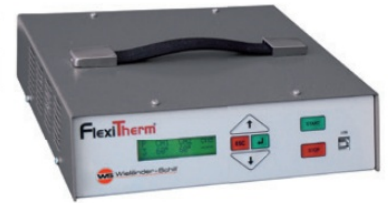

Scope of delivery:

- 1 x Control unit 220/240 volt
- 3 x Heating pads
- 20 x Fixing magnets
- 50 x Sheets of non-stick paper
- 1 x Roll of adhesive tape (25 m)
- 1 x CD-ROM with FT Control software
- 1 x USB cable
- 1 x Instruction manual
- 1 x Carrying case

FlexiTherm accessories

Item no.	701055	701051	701052
Name	Fixing magnets	FIX-Tape Adhesive tape for alu, glass, etc.	FIX-Tape Adhesive tape for alu, glass, etc.
QTY	10 pcs.	25 m	50 m



FlexiTherm accessories

Item no.	701050	701060
Name	Non-stick paper	Heating pad
QTY	50 pcs.	1 pc.



Japan scraper set | 4-piece

Item no. 541020

For applying as well as smoothing filler and plaster.



Teroson spatula

Item no. 541011

With stainless steel reinforced handle-end



Brushes

Item no.	541101	541103	541250	541290
Name	Brush G10 long-bristled	Flat brush G5	Flat brush nylon 3M	Paint brush size 2
QTY	1 pc.	1 pc.	1 pc.	1 pc.



Dust cloth | 600 x 350 mm

Item no. 541280

General-purpose dust-binding cloth with effective adhesive formula for all cleaning tasks prior to the application of base materials and conventional topcoat products. Due to the use of modern spunbond technology, this cloth is extremely low linting and does not fray.

Scope of delivery:
10 x Dust cloth



W+S 2-C Aluminium-Plastic set

Item no. 542050

The aluminum 2-component filler was specially developed for the repair of damaged, aluminum car bodies. The metal filler is easy to draw and sand and has high stability and temperature resistance, making it particularly suitable for overpainting.

Scope of delivery:
1 x Metal powder 1000 g
1 x Hardener liquid 350 g
1 x Skin protection cream
1 x Protective gloves
1 x Mixing cup
2 x Wooden spatulas



Item no.	542051	542052
Name	W+S 2-C Aluminium Plastic (metal powder) 1000 g	Hardener liquid for W+S 2-C ALU 350 g
QTY	1 pc.	1 pc.



W+S 2-C Steel-Plastic set

Item no. 542055

Metal filler for the finishing process after dent removal. The mixing ratio can be dosed variably according to the area of application.

Scope of delivery:
1 x Metal powder 1130 g
1 x Hardener liquid 220 g
1 x Skin protection cream
1 x Protective gloves
1 x Mixing cup
2 x Wooden spatulas



Propan burner set incl. wooden box

Item no. 802001

The complete set with all important and necessary accessories including pressure reducer for small and also large gas bottles.

Scope of delivery:

1 x Wooden case	1 x Quick connection valve
1 x Handle straight	1 x Hook
1 x Pointed burner 9 mm	1 x Refill adapter
1 x Cyclone burner 18 mm	1 x Regulator-valve small 2 bar 7 kg DIN/combi
1 x Hot air burner	1 x Regulator-valve large
1 x Gas bottle	1 x HP hose 2 m 4.4 mm
	1 x Open-end wrench



Power Jet - burner set

Item no. 802100

Scope of delivery:

- 1 x Power Jet with cyclone burner
- 1 x Gas bottle 2000
- 1 x Refill adapter



Gas bottle 2000

Item no. 808020

Refillable propane gas cylinder made of high quality steel. The bottle is corrosion-protected on the inside and has a protective coating on the outside. It is equipped with type approved valves and has a safety valve to prevent overpressure.



1000 ml capacity

Handles

Item no.	801100	808001
Name	Power Jet with cyclone burner	Burner handle
VE	1 pc.	1 pc.

Suitable for all types of brazing, soldering, shrinking and all other heating operations.

The PowerJet operates with a variety of gas mixtures. These include: Propane-Butane mixtures, Sievert Ultra gas, as well as Mapp® and Ultramapp gas for high flame temperatures.



Automatic piezo ignition guarantees more than 30,000 ignitions. Universal handle with integrated piezo ignition with on/off function.

Rotatable hose connection prevents twisting of the hose. Connection R3/8 „li.

Burners

Item no.	808100	808003	808004	808005
Name	Cyclone burner	Pointed burner bent	Hot air burner bent	Cyclone burner bent
VE	1 pc.	1 pc.	1 pc.	1 pc.

For brazing and soldering work. The powerful whirling flame ensures an even heating.



Power at 2 bar- 2.2 kW
Hard soldering at 2 bar - Ø 18 m

Soft soldering at 2 bar - Ø 40 mm
Gas consumption at 2 bar - 170 g/h

very fine flame for precision brazing



for all work where an open flame would cause material damage

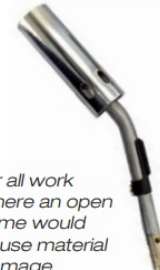

rotating vortex flame guarantees even heating of the material



Accessories

Item no.	808021	808022	808023	808027	808028
Name	Quick connect valve for gas bottle	Pressure regulator valve Cylinder connection & Hose connection R3/8" li	Pressure regulator valve Cylinder connection DIN Combi Hose connection R3/8" li	Refill adapter DIN Combi Connection: DIN Combi M14 x 1.5	excess flow cut-off valve Connection: R3/8" x R3/8" li
VE	1 pc.	1 pc.	1 pc.	1 pc.	1 pc.

Pressure regulator with fixed working pressure of 2 bar.
Maximum flow rate is 6 kg/h.



High pressure hose

Item no. 808025

High pressure hose according to DIN 4812 made of rubber with textile insert.
The special rubber compound is frost-resistant and thus allows work down to -30 °C.
For all soldering work up to a working pressure of 2 bar.
Pre-assembled with hose connections R3/8" le.



WS Tinning set

Item no. 812005

The complete set for tinning.
Bar tin - 25% lead content

Scope of delivery:

- 1 x Power Jet with cyclone burner
- 1 x gas bottle empty (f. propane or butane)
- 1 x refill adapter
- 1 x Solder paddle | oiled | round
- 1 x Solder paddle | oiled | narrow
- 1 x Solder paddle | oiled | wide
- 1 x tinning paste SN97CU3
- 1 x bar tin - 25% lead content



Bar tin

Item no.	817010	817009
Name	Bar tin 25% lead content	Bar tin lead-free
VE	1 kg	5 kg

Bar tin according to DIN EN 29453.
Can be processed very well, retains its "pasty" state for a long time.



Melting temperature 200-250 °C.
Electrical conductivity 22.6 Sm/mm²
Specific weight 7.3 g/cm³
Hardness (solder) 16 HB



Tinning			
Item no.	817003	817002	817020
Name	Tinning paste Sn97Cu3 lead free 1000 g	Tinning paste AP 644/12 lead free 1000 g	Tinning wax 1300 g
VE	1 pc.	1 pc.	1 pc.



Solder Paddles			
Item no.	812001	811002	811003
Name	Solder paddle set 3-piece	Solder paddle oiled round	Solder paddle oiled narrow
VE	1 pc.	1 pc.	1 pc.



Hot air hand tool - Leister Electron ST3400

Item no. 801201

With improved ergonomics and therefore more working comfort. Existing nozzles can still be used. The temperature is steplessly adjustable from 40 °C (104 °F) to 650 °C (1202 °F). The air filters integrated in the handle can be easily removed and cleaned. Integrated carbon brake and heating element cover ensure workplace safety and make this heat gun a perfect tool for all job sites.

A transport case is included in the scope of delivery.



Induction heating device i-Ductor EVO 03

Item no. 842110

Fast, efficient, easy to use. Ideal for removing car windows, bolts and also all types of materials glued on metal support without damaging the piece. It allows the removal of heated rear windows, side windows, mouldings, adhesives without leaving a sticky residue, damping, paint, adhesives, sealants, soundproofing material.

The inverter brings an alternating current of 230 V, 50 Hz to a high frequency, which converts the device (washer-dissolver or heating glove) into a high-frequency alternating magnetic field. The magnetic field penetrates the conductive metallic work surface (e.g. a car body sheet) and causes the electrons in the metal to oscillate according to the principle of electromagnetic induction. The kinetic energy of the electrons in motion is dissipated in the form of heat, which heats the metal in the working area of the device (about 12-25 mm). The more easily a substance magnetizes, the greater the heat that develops within it. For this reason, the I-Ductor very quickly heats ferrous metals and their alloys but does not affect glass, plastic, wood, clothing and other non-conductive materials.



Cartridge guns | 50 ml

Item no.	831100	831106
Name	MR 50 for Betamate 2096 - 50 ml	VBM (MR) 200 for Betamate 2096 - 200/215 ml
VE	1 pc.	1 pc.

The MR50 can be used with all 50 ml models of S-type and rectangular cartridges. Only one gun is needed for 25 ml, 50 ml and 75 ml cartridges.

An ergonomically shaped handle and trigger are designed to produce high force pressure with ease and comfort - even for highly viscous materials. A simple folding mechanism ensures safe and correct loading of the cartridge and provides optimal material dispensing.



EPX50

Item no.	831101	838115
Name	EPX50 for two-component body adhesive cartridges 50 ml	Mixing tube EPX for 50 ml cartridge
VE	1 pc.	1 pc.



ElectraFlow | Battery cartridge gun

Item no. 831105



For cartridges + foil bags

The ElectraFlow Plus is designed for professionals in different work areas who demand a reliable tool that delivers high performance. Pressure adjustable with locking button - noticeable relief for long seams, with high power battery (NiMH).

Advantages:

- lightweight handle and motor unit with soft cover for longer work
- new built-in storage pads to protect the gun from scratches and slippage
- easy-to-use barrel lock to prevent accidental material spillage
- covered handle (soft rubber), for comfortable and long working time
- adjustable thrust power (9 speeds) to set the speed of material discharge
- driving force up to 350 kg (3.5 KN)
- for bags up to 600 ml

Air Flow | pneumatic

Item no. 831103



Accessories ElectraFlow

Item no.	831107	831108
Name	Spare battery for ElectraFlow	Charger for battery ElectraFlow
VE	1 pc.	1 pc.



Fix magnets set | 4 pcs.

Item no. 882055

The easy way to fix mounting parts and protective blankets.

Scope of delivery:
4 x Magnet
4 x Handle



Fix magnet - spare parts

Item no.	881340	881341
Name	Magnet	Handle
VE	1 pc.	1 pc.



Fixing brackets set | 3 pcs.

Item no. 882057

An accessory for the Fix Magnets to fix side trimmings, lights and side windows. Very important when bonding to keep the parts in place during drying.

Scope of delivery:
1 x Fixing bracket flat | 831245
1 x Fixing bracket flat | 831246
1 x Fixing bracket deep | 831247



Fixing brackets

Item no.	881345	881346	881347
Name	Fixing bracket flat h = 30 mm	Fixing bracket flat h = 50 mm	Fixing bracket deep h = 50 mm
VE	1 pc.	1 pc.	1 pc.



Suction lifter with T-handle and eyelet

Item no. 881350

For mounting and dismounting of rear view mirrors etc.

The solid rubber suction lifter can be used individually due to the two different adaptation options. The rubber disc with threaded insert is used on the one hand in conjunction with the eyelet for quick attachment of various end products and on the other hand in conjunction with the T-handle for lifting and transporting different materials such as glass, plastic surfaces, etc.. The rubber washer can be easily detached from the surface with the fingers due to the notch along the diameter.



Maximum load capacity 15 kg with vertical carrying direction.



Easy marking and tracing of curved, round wheel arch lines, design lines on doors, windows, etc.

Extendable in size
40 - 160 mm

Sturdy metal construction

Built-in pencil sharpener

Excellent preparation for grinding

The line marker helps you trace and mark the original body lines of a vehicle in one movement. The enclosed pen marks the outer body lines of the vehicle shape, even on difficult round and curved car parts such as wheel housings, doors, etc.

Optimised sanding process due to accurate marking.

BODY LINE MARKING TOOL

Body Line Marking Tool

Item no. 871015

Application

Start by applying the putty or primer to the object, dry it, mark the object's body lines, use surface protection tape if necessary and start sanding. This is how you recreate the original body lines of the vehicle.

Scope of delivery:
1 x Body line marking tool
1 x Charcoal pencil

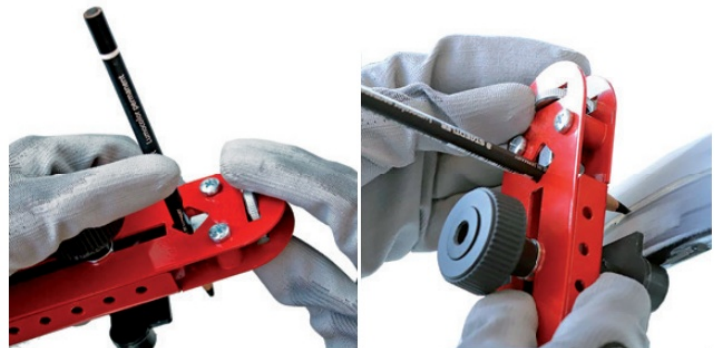

WS WIPER tool kit - removal tool for wiper arms

Item no. 881355



Scope of delivery:
2 x WS WIPER Tool



Flexible magnetic pick-up tool

Item no. 881320

Magnetic lifter with flexible steel shaft for picking up small parts in hard-to-reach places.

Pulling force 1800 g



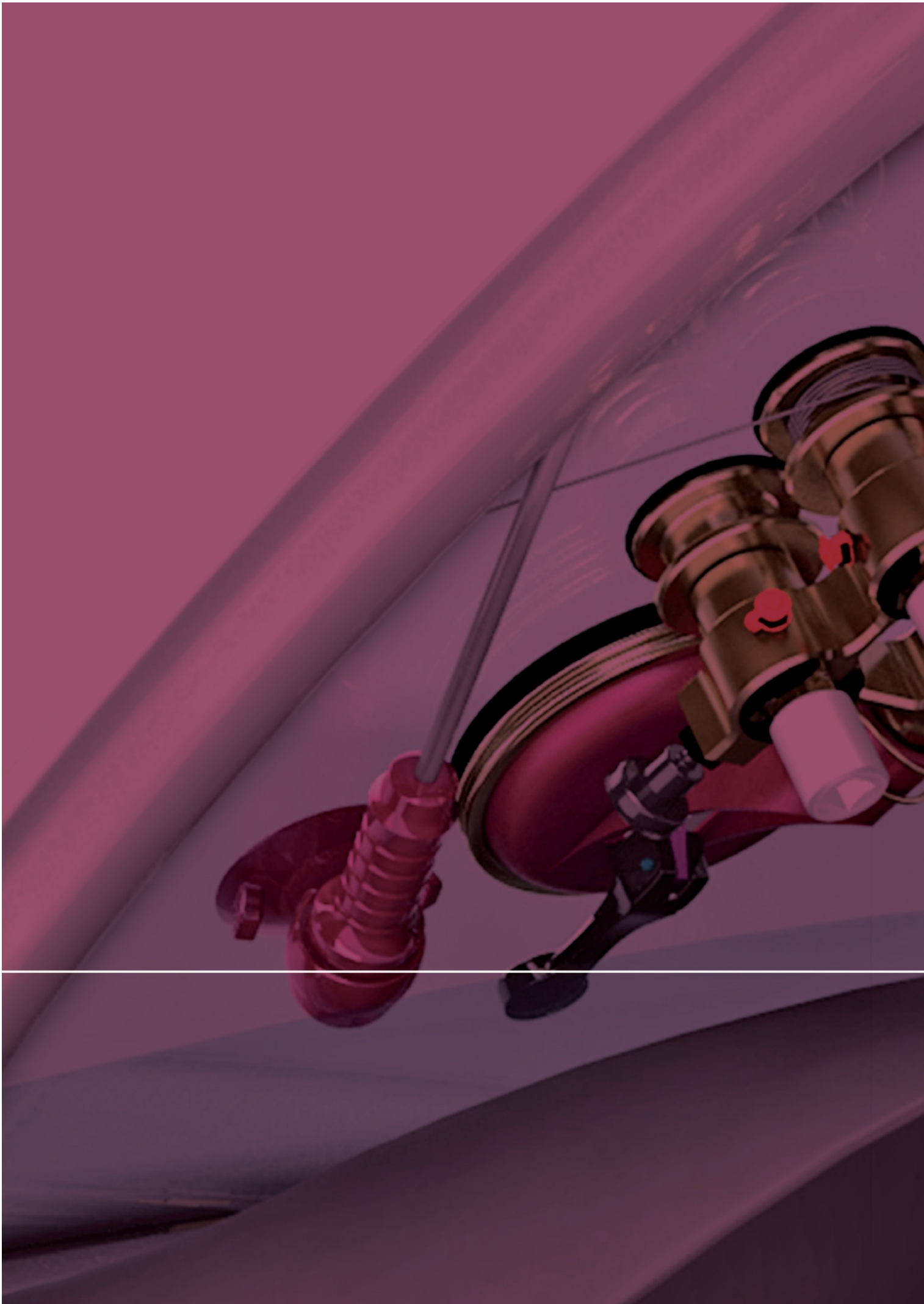



Roll Out 2000[®]

WINDSHIELD REMOVAL SYSTEM



**EASY
HANDLING**

**LOW
COSTS**

**NO ADDITIONAL
TOOLS ARE
NEEDED**

Roll Out 2000®

CAR WINDOW REMOVAL TOOL

Window removal system for all adhesively attached vehicle windows. Only one operator is required for the application. Damage to the paint is avoided, eliminating the need for touch-ups. A minimal tolerance between the windshield and the car body is no problem! No power source/battery is required.

Roll Out 2000® - Model 2020 CF | Constant Friction
Item no. 842020

The Roll Out 2020 CF (*Constant Friction*) is the logical and innovative development of the proven Roll Out 2000 car window repair system.

The Constant Friction function simplifies the repair process and makes the removal of vehicle windows more reliable. The risk of the cutting wire or Kevlar cord being torn off is significantly reduced.



Scope of delivery:

- 1 x Parabolic chisel
- 1 x PushPull wire insertion tool (awl)
- 1 x Double spool device
- 1 x Safety goggles
- 1 x Kevlar Cord | 25 m
- 1 x Cutting wire | dia. 0.75 mm x 350 m
- 1 x Protective gloves
- 1 x Tool bag

- 2 x Mounting wedge
- 1 x Switch ratchet | large
- 1 x Ratchet | small
- 1 x Protective template
- 1 x Extension | 75 mm
- 1 x Extension | 150 mm
- 1 x Needle set
- 1 x Tool box
- 1 x Repair instructions



recommended by
RENAULT

Roll Out 2000® - Model 2004

Item no. 842010

The adhesive is cut with a round wire. For a stronger glue seam, the „Power Slide“ (roll wire from one spool to the other) can be used. This heats up the wire and the glue seam a little and the windscreen can be removed easily.

- optimal cutting angle
- very easy application of the cutting wire in all areas
- use for cars, vans and trucks
- no other tool required

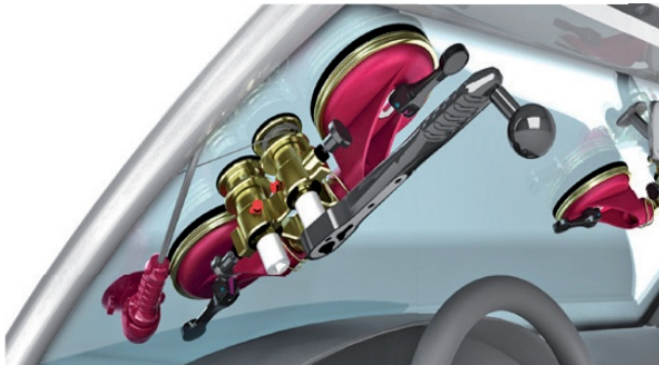

OEM
 recommendation



Scope of delivery:

- | | |
|---|--------------------------------------|
| 1 x Parabolic chisel | 2 x Mounting wedge |
| 1 x Wire insertion tool | 1 x Switch ratchet large |
| 1 x Single spool device | 1 x Protective template set (2 pcs.) |
| 1 x Double spool device | 1 x Extension 75 mm |
| 1 x Safety goggles | 1 x Needle set |
| 1 x Cutting wire dia. 0.75 mm x 350 m | 1 x Tool box |
| 1 x Protective gloves | 1 x Repair instructions |
| 1 x Tool bag | |

Upgrade Kit Roll Out 2000® - Model 2020 CF

Item no. 848084

Upgrade kit for the 2004 model

Upgrade your 2004 model to the new 2020 Constant Friction model in no time and without any problems. All existing tools and the cutting wire can still be used.

More control and comfort in just a few easy steps.

Scope of delivery:

- 1 x Double spool device with Constant Friction function
- 1 x Ratchet small



Suction device for side window guide

Item no. 848056

Corner Extension

Item no. 848081

Rocker lever Rep.-Kit

Item no. 848083



Roll Out 2000® - Model 2020 CF

Winches with suction cups

Item no.	848088
Ø	120 + 150 mm
Variant	2-spool
QTY	1 pc.



Roll Out 2000® - Model 2004

Winches with suction cups

Item no.	848039	848041	848005	848040
Ø	120 mm	150 mm	120 mm	150 mm
Variant	2-spool	2-spool	1-spool	1-spool
QTY	1 pc.	1 pc.	1 pc.	1 pc.



Roll Out 2000® - Model 2004

Winches

Item no.	848048	848053	848060
Typ	2-spool	1-spool	Locking switch
QTY	1 pc.	1 pc.	1 pc.



Suction holder

Item no.	848020	848021	848022	848023
Ø	120 mm	120 mm	150 mm	150 mm
QTY	1 pc.	2 pcs.	1 pc.	2 pcs.



Suction device for winches

Item no.	848046	848047	848050	848051
Ø	120 mm	120 mm	150 mm	150 mm
QTY	1 pc.	2 pcs.	1 pc.	2 pcs.



Accessories

Item no.	848027	848028	848087	848038	848033
Item	Switch ratchet large	Spherical handle	Ratchet small	Extension for switch ratchet 75 mm	Extension for switch ratchet 150 mm
QTY	1 pc.	1 pc.	1 pc.	1 pc.	1 pc.



Unroll device for cutting wire

Item no. 848006

Safe and protected storage of the cutting wire. Easy unwinding and measuring of the necessary length.



Cutting wire 0.75 mm x 1500 m

Item no. 842015

The cutting wire with „soft“ surface is extremely resilient and very flexible, and its properties ensure damage-free removal of windshields and much more.



Kevlar Cord | 25 m

Item no. 848085

Kevlar is extremely low-stretch, tensile & load resistant, durable, dimensionally stable, abrasion-resistant, and resistant to frictional heat, making it perfect for windshield removal.



Fix-Cut 1 - Scraper Blades Set

Item no. 547032

- Professional scraper blades
- Compact handle transmits the power excellently
- Blades with convex back for removing the PU adhesive according to specifications
- Side wings of the blades rounded
- Perfect individual tuning of blade sharpness
- Correct thickness of adhesive will remain for re-bonding

Scope of delivery:

2 x 20 mm scraper (547033)

2 x 25 mm scraper (547034)

2 x Handle

1 x Silicon carbide grinding stone

1 x Wrench

1 x Transport case

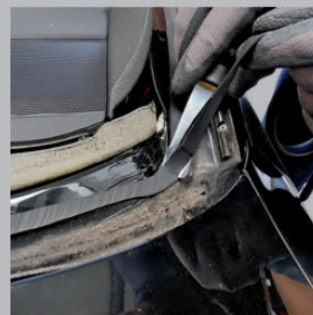
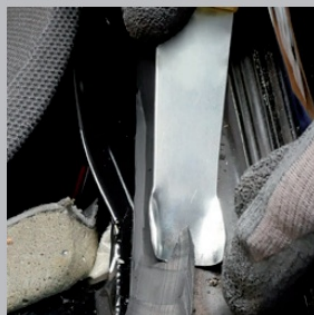
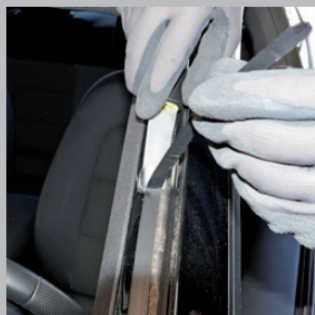

Spare parts Fix-Cut 1

Item no.	547033	547034	547037	547035
Width	20 mm	25 mm		
QTY	1 pc.	1 pc.	1 pc.	1 pc.



Scraper set

Item no.	848011	848012	848013	848014
Width	12 mm	16 mm	20 mm	
QTY	10 pcs.	10 pcs.	10 pcs.	1 pc.



Interior protection

Item no.	848003	848034	848035	848036
Item	Set 4 pieces	Dashboard	A-pillar + headliner	round - Ø 120 mm
QTY	1 pc.	1 pc.	1 pc.	1 pc.



PushPull wire insertion tool

Item no. 848090



Wire insertion tool

Item no. 848001



Parabolic chisel

Item no. 848007



Mounting wedges set | 2 pcs.

Item no. 848029



Suction holder for chisel

Item no. 848061



Quick release

Item no. 848052



Protective gloves

Item no.	848002	848009
Size	9	10
QTY	1 pair	1 pair



Safety goggles

Item no. 848032



Needles

Item no.	848004	848031	848026
Item	Set 8 + 2 pcs.	Führungsnadel	Gebogene Nadel
QTY	1 pc.	10 pcs.	3 pcs.

For threading the cutting wire in tight places.
To „support“ and „guide“ the wire over problem areas.



Applicators | wool wipers 130 mm

Item no.	848016
Item	Cotton applicators
QTY	100 pcs.

For clean, accurate application of black primer, primer, adhesive cleaner, etc.
The full, densely loaded head results in a lint-free, uniformly covering application of material.



Transport case | RO 2020 CF

Item no. 848024



Transport case | RO 2004

Item no. 848025



Tool bag

Item no. 848042



Delivery without content

Removal kit for side windows

Item no. 848008

for Opel Meriva



Glass removal kit for side windows

Item no. 848044

for Opel Vivaro







WS WHEEL DOLLIES



SELF-LOADING WHEEL DOLLIES

The design of the wheel dollies is based on the idea of moving and manoeuvring vehicles in repair or body shops and show-rooms. However, the WS Wheel Dollies have also proven indispensable in emergency operations and across parking lots. Lifting and moving vehicles in any direction can be done very quickly and easily with only 4-5 pumps, without any major effort.

**DIFFERENT
AXLE WIDTHS**

**DIFFERENT
WHEEL SIZES**

**DIFFERENT
TIRE WIDTHS**

**2 YEARS
WARRANTY**

**WS
WHEEL DOLLY**

OEM

Model overview

Model	4500	5211 R	5211 L	6200 R	6200 L	SUV	Sports Car
Load rating	510 kg	590 kg	590 kg	715 kg	715 kg	794 kg	816 kg
Wheel sizes	20" - 36"	11" - 34"	11" - 34"	13" - 36"	13" - 36"	20" - 33"	13" - 22"
Tyre widths	500 mm	270 mm	270 mm	330 mm	330 mm	400 mm	500 mm
Item no.	851000	851001	851007	851002	851003	851004	851006

Wheel Dolly 4500

Item no. 851000

The Wheel Dolly 4500 was developed for the racing car industry. Cars with tyre widths from 20 inches to 36 inches can be moved effortlessly. The device is designed for vehicle weights up to 2 tons. Twin rollers on each axle guide the tyre smoothly up and over the axle support bar to lift wider tyres



Set up			Tech. Data				
Load rating max.	Tyre widths	Wheel sizes	Unit weight	Mechanism	Contact rolls	Castors	Design
510 kg (1 pc.)	up to 500 mm	20" - 26"	19.5 kg	Double pawl	4 pcs. (2 x 2)	4 x 3"	Steel frame
2.04 t (4 pcs.)			Galvanized steel				

Info

Required for one vehicle:
2 × right version, 2 × left version

Wheel Dolly 5211 R/L

Item no. 851001 right version

Item no. 851007 left version

The Wheel Dolly 5211 is a proven and reliable product and shouldn't lack in any workshop. The model 5211 can lift tyre widths up to 270 mm and wheel sizes between 11 and 34 inches and thus accom-

modate a very high percentage of cars and light trucks sold today. It uses a bi-directional linear ratchet for the jack portion and has a 5-degree offset pedal angle for additional foot-to-tire clearance.

Right version**Left version**

Set up			Tech. Data				
Load rating max.	Tyre widths	Wheel sizes	Unit weight	Mechanism	Contact rolls	Castors	Design
590 kg (1 pc.)	up to 270 mm	11" - 34"	13.7 kg	Double pawl	2 pcs.	4 × 4"	Steel frame
2.36 t (4 pcs.)					Galvanized steel		

Wheel Dolly 6200 R/L

Item no. 851002 right version

Item no. 851003 left version

The model 6200 is an absolute workhorse due to the high-strength steel rollers and heavy-duty nylon casters with double ball bearings and is particularly suitable for vehicle weights up to 2860 kg and tire widths up to 330 mm. The special design en-

ures smooth movement under heavier loads. Equipped with the largest rollers of the product line, which allow further ground clearance, the model is unbeatable especially when lifting cars onto a low loader.

Right version**Left version**

Set up			Tech. Data				
Load rating max.	Tyre widths	Wheel sizes	Unit weight	Mechanism	Contact rolls	Castors	Design
715 kg (1 pc.)	up to 330 mm	13" - 36"	17.5 kg	Double pawl	2 pcs.	2 × 4" + 2 × 5"	Steel frame
2.86 t (4 pcs.)					Galvanized steel		

Wheel Dolly Trolley

Item no. 851010

Stores and moves 4 Wheel Dollies in a convenient and orderly manner. Suitable for all wheel dolly models.



Delivery without Wheel Dollies

Wheel Dolly SUV

Item no. 851004

The Wheel Dolly SUV pushes the limits of what can be moved with a dolly even further.

Specially designed to handle SUVs up to 3175 kg with ease in the workshop or showroom floor.



Set up			Tech. Data				
Load rating max.	Tyre widths	Wheel sizes	Unit weight	Mechanism	Contact rolls	Castors	Design
790 kg (1 pc.)	up to 400 mm	20" - 33"	24 kg	Double pawl	4 pcs. (2 x 2)	4 x 3.5"	Steel frame
3.175 t (4 pcs.)					Galvanized steel		

Wheel Dolly SUV - set

Item no. 851015

Scope of delivery:
4 x Wheel Dolly SUV
1 x Trolley



Wheel Dolly Sports Car - set

Item no. 851006

The Sports-Car-Set was developed for the racing car industry. Cars with wheel sizes from 13 to 22 inches can be moved effortlessly. The set is designed for vehicle weights up to 3.25 tons. Twin rollers on each axle guide the tire smoothly up and over the axle support bar to lift wider tyres.

Scope of delivery:
 4 x Wheel Dolly Sports Car
 1 x Trolley



Set up			Tech. Data				
Load rating max.	Tyre widths	Wheel sizes	Unit weight	Mechanism	Contact rolls	Castors	Design
816 kg (1 pc.)	up to 500 mm	13" - 22"	19.5 kg	Double pawl	4 pcs. (2 x 2)	6 x 3"	Steel frame
3.26 t (4 pcs.)					Galvanized steel		



OEM
 APPROVAL



Spare wheels

Model	4500	5211 R	5211 L	6200 R	6200 L	SUV	Sports Car		Item no.
3" / 72.6 mm	•						•	1 pc.	854006
3.5" / 89 mm						•		1 pc.	851005
4" / 100 mm		•	•	•	•			1 pc.	854007
5" / 125 mm				•	•			1 pc.	854008

Model 6200 is equipped with 2 x 4" and 2 x 5" wheels

Spare wheel sets

Item no.	854009	854004	854005
Name	Spare wheel set Model 6200 2 x 4" & 2 x 5"	Locknut for 4" wheel	Locknut for 5" wheel
QTY	1 pc.	1 pc.	1 pc.



Spare parts

Item no.	854018	854017	854016	854015	854014
Name	Lever claw	Torsion spring	Locking pawl	Working pawl spring	End stop 25.5 mm
QTY	1 pc.	1 pc.	1 pc.	1 pc.	1 pc.



Item no.	854013	854012	854029	854026	854028
Name	Self-tapping hex bolt	End stop clip & spring	Steel roller 2.5"	Steel roller 1"	Screw for roller 1"
QTY	1 pc.	1 pc.	1 pc.	1 pc.	1 pc.



Item no.	854027	854025	854023	854022	854020
Name	Roller raceway (Nylon)	End stop 19.5 mm	Upper pivot shaft	Washer	Locking pin
QTY	1 pc.	1 pc.	1 pc.	1 pc.	1 pc.







A person wearing a white protective suit and gloves is working on a piece of equipment, possibly a storage system. The image is overlaid with a green tint. The person is using a tool to work on a component of the equipment. The background is dark and out of focus.

PAINTING EQUIPMENT
AND STORAGE SYSTEMS



Cleaning system for paint shop equipment

PROLAQ WS powerfully removes paints, lacquers and printing inks at a much lower workplace risk potential than conventional thinners such as acetone or ethyl acetate. Carefully selected raw materials ensure a low VOC content of the cleaners, minimal odor pollution and a pleasant working atmosphere.



FOR WATER-BASED AND SOLVENT-BASED PAINTS

VERY LONG SERVICE LIFE

LOWER DISPOSAL AND HANDLING COSTS

STRONG CLEANING POWER

FOR AUTOMATIC CLEANING MACHINES AND MANUAL DEVICES

PROLAQ WS

CLEANING SOLUTIONS





CLEANING

WATER-BASED COATINGS SOLVENT-BASED COATINGS

- Removes primarily solvent-based and water-based paints and varnishes
- Cleans all paint application tools, varnish pumps, printing rollers etc.
- Can be used automatically and manually
- Can be reused in a closed loop
- Long service life
- VOC-reduced and label-free according to CLP regulation
- Protection for employees and the environment

VERSATILE

CLEANING SOLUTIONS

Modern cleaning systems are characterized by economic efficiency and resource conservation. These are the main strengths of the cleaners from the PROLAQ WS family.

They powerfully remove paints, lacquers and printing inks at a much lower workplace risk potential than conventional thinners such as acetone or ethyl acetate.

Carefully selected raw materials ensure a low VOC content of the cleaners, minimal odor pollution and a pleasant working atmosphere.

Whether solvent-based or water-based paints, the PROLAQ system offers an optimal solution for every application.

Multi-stage sedimentation makes it possible to increase the service life of PROLAQ WS and improve process reliability during gun cleaning.

SEDIMENTATION TANK

The cleaning fluid is directed into the innermost segment during sedimentation, then runs from segment to segment due to the interleaved internal parts, with sedimentation occurring in each segment.

In the outermost segment, which is enclosed by the outer tank, the treated cleaning fluid can be removed.

The sedimentation insert can be completely disassembled and thus enables easy cleaning of the system.

APPLICATION



RINSING

CLEANING RESIDUES DUST, LIGHT FATS AND OILS

Water-based, surfactant-free cleaner, VOC content less than 20%.

Removes any cleaning residues

Removes dust, light fats and oils

Removes felt-tip pen

Removes fingerprints

For manual and automatic use

Fast

Residue-free

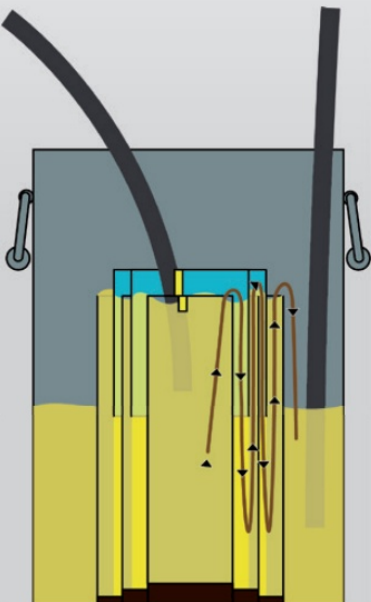

PROLAQ WS starter set

Item no. 837236

Detailed information on page 165-167

Scope of delivery:
 1 x 837229 PROLAQ WS sedimentation tank
 1 x 837230 PROLAQ WS
 1 x 837235 PROLAQ WS Rinse



PROLAQ WS sedimentation tank

Item no. 837229

FOR SEDIMENTATION OF PROLAQ WS.

The sedimentation insert can be completely disassembled and thus enables easy cleaning of the system.

Scope of delivery:
 1 x Stainless steel tank (30 l)
 1 x sedimentation insert (5 pcs.)



PROLAQ WS

Item no. 837230

For the removal of solvent-based and water-based paints and varnishes

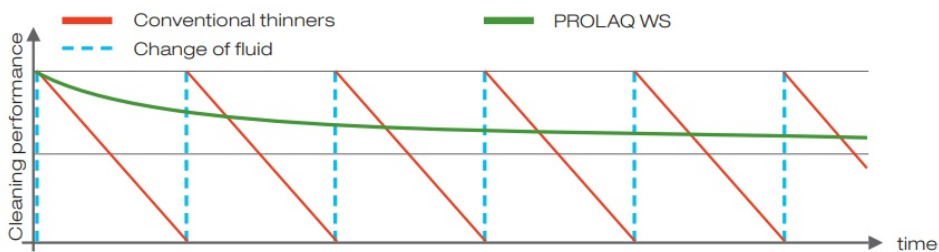

PROLAQ WS Rinse

Item no. 837235

For the rinsing of painting tools after cleaning with PROLAQ WS.

After cleaning with PROLAQ WS cleaners, rinse the painting tools manually in an immersion bath with PROLAQ WS Rinse. For machine use, add the rinsing liquid to the PROLAQ cleaning system.



CLEAN

BLOW DRY

RINSE

BLOW DRY

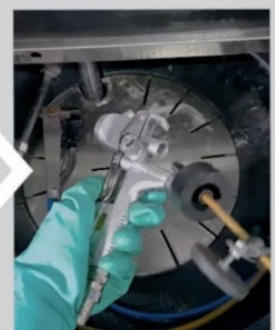
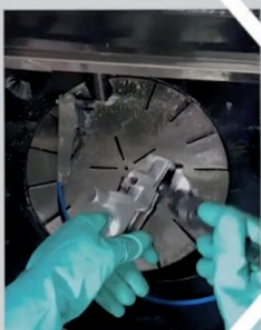

PROLAQ WS

PROLAQ WS Rinse



AUTOMATIC AND MANUAL WASHING OR RINSING

TIMER FOR INDIVIDUAL CLEANING TIME

SIMULTANEOUS AUTOMATIC CLEANING OF 2 SPRAY GUNS

AUTOMATIC EXTRACTION IN THE WORKING AREA

STAINLESS STEEL HOUSING

HIGH QUALITY DIAPHRAGM PUMP

ARTEX II 2G PROTECTION CLASS

SPRAY GUN WASHER

Automatic washer for paint guns made of stainless steel with separate circuits for cleaning and rinsing liquid. Optimal for the use of Prolaq WS.

The pre-cleaning and main cleaning is carried out in the automatic area, which is separated from the manual rinsing area. Both areas feature separate drains so that the liquids cannot mix.

WSM30 + KIT M

Spray gun washer WSM30 + Kit M

Item no. 837253

Scope of delivery:

- | | |
|------------------------------------|---------------------------------|
| 1 x Spray gun washer | 2 x plastic clamp for spray gun |
| 1 x flexible hose 1 m Ø 100 mm | 1 x ground cable |
| 2 x washing brush | 1 x compressed air line 2 m |

Protective gloves | neoprene

Item no. 881055

Super strong protection - cotton lined rubber gloves with neoprene coating

- | | |
|----------------------|--|
| • chemical resistant | • thickness 0.7 mm |
| • grease repellent | • Velourized |
| • food safe | • EN 388/374 / EN ISO374-5-2016 |
| • Fully dipped | • One size fits all (corresponds to size 10) |



Cleaning brush for spray gun washer

Item no. 837853



PDL-Liquid | Cleaning fluid

Item no. 697001

Compressed air cleaning fluid for all dusts, oils and other impurities of the painting compressed air system.

PDL liquid is replaced in a few minutes, is absolutely unproblematic and can be disposed of very easily later. Consumption: approx. 2 bottles per month (approx. 4-6 weeks).

Scope of delivery:

9 x PDL-Liquid | 200 ml



UltraRack

Item no. 881104

Paint stands for:

- Hoods
- Tailgates
- Doors
- Lift gates
- Deck lids
- Fenders

Seven locking positions mimic the parts position on the vehicle for a seamless match. 90° rotation to achieve the right color coverage every time. Built-in rubber shoes protect critical areas from overspray. This paint stand features four industrial-grade total-lock caster wheels that provide stability while you work. Features long-lasting powder coat finish.



SuperStand

Item no. 881103

Paint stands for:

- Bumpers
- Spoilers
- Front skirts
- Rear skirts

The innovative bumper repair stand boosts your profits by speeding up repair, prep, and painting times and reducing costly paint mistakes! It holds any plastic bumper cover without touching the painted surface.

Five positions mimic the part's place in the car for a seamless match. 90° rotation to achieve proper paint coverage every time. Built-in rubber boots protect critical areas from over-spray. Four industrial-grade, total-lock caster wheels for stability; zero movement when locked. Features long-lasting powder coat finish.



X-Stand

Item no. 881105

Complete flexibility - both horizontally and vertically, the X-Stand can be adjusted for any task.

Perfect for door skin replacement & transferring bumper components. Padded support surfaces adapt to the contour of the sheet metal or car window. Set your ideal working height. Sheet metal and windows of virtually any size can be processed. The industrial-grade caster wheels allow the stand to be easily moved throughout your body shop. With long-lasting powder coating.



MegaStand

Item no. 881106

Mobile storage system for up to six large panels and glass

With the extensive foam and rubber padding, doors, hoods, tailgates, etc. can be put down easily and without metal contact. The risk of damage is thereby set to zero.

The Megastand can be used as whole or as a half space-saving unit by simply folding up one side of the system.



BumperStand

Item no. 881107

Mobile storage system for up to eight bumpers

- Four extra long arms for very large bumpers
- Support arms are fully adjustable at 7.6 cm intervals
- Hardened steel construction withstands heavy loads
- Four locking wheels for easy mobility; zero movement when locked
- Durable powder-coat finish stands up to rough handling



Body Shop Manager

Item no. 881100

Small footprint - big effect

- Space saving storage
- 30% more storage space than comparable products
- Heat-treated high-carbon steel storage surfaces
- Fall-out protection for tools
- Four industrial-grade caster wheels have a total-lock feature that prevents any movement when locked
- With long lasting powder coat finish



Workshop Manager Accessories

Item no.	881180	881181	881194
Name	Additional Arms for Workshop Manager	Foam sleeves for additional arms	Rubber insert for storage baskets
Dimensions	500 x 70 x 25 mm	Ø 60 mm L = 450 mm	1000 x 550 mm
VPE	2 pcs.	2 pcs.	1 pc.



Tool trolley with telescopic rear panel

Item no. 881200

Features

- Steel top
- Back wall can be lowered (also with tools)
- 9 drawers
- 2 fixed castors
- 2 swivel castors with locking brake



Tool Trolley with Cabinet

Item no. 881205

Features

- Beech top
- 5 drawers
- 1 base cabinet
- 1 cabinet top
- 2 fixed castors
- 2 swivel castors with locking brake



Tool Trolley R230

Item no. 881201

Features

- Steel top
- 8 drawers
- 2 fixed castors
- 2 swivel castors with locking brake



Werkzeugwagen mit Schrankaufsatz

Item no. 700010

Features

- Beech top
- 5 drawers with anti-slip mats
- 2 fixed castors
- 2 swivel castors with locking brake







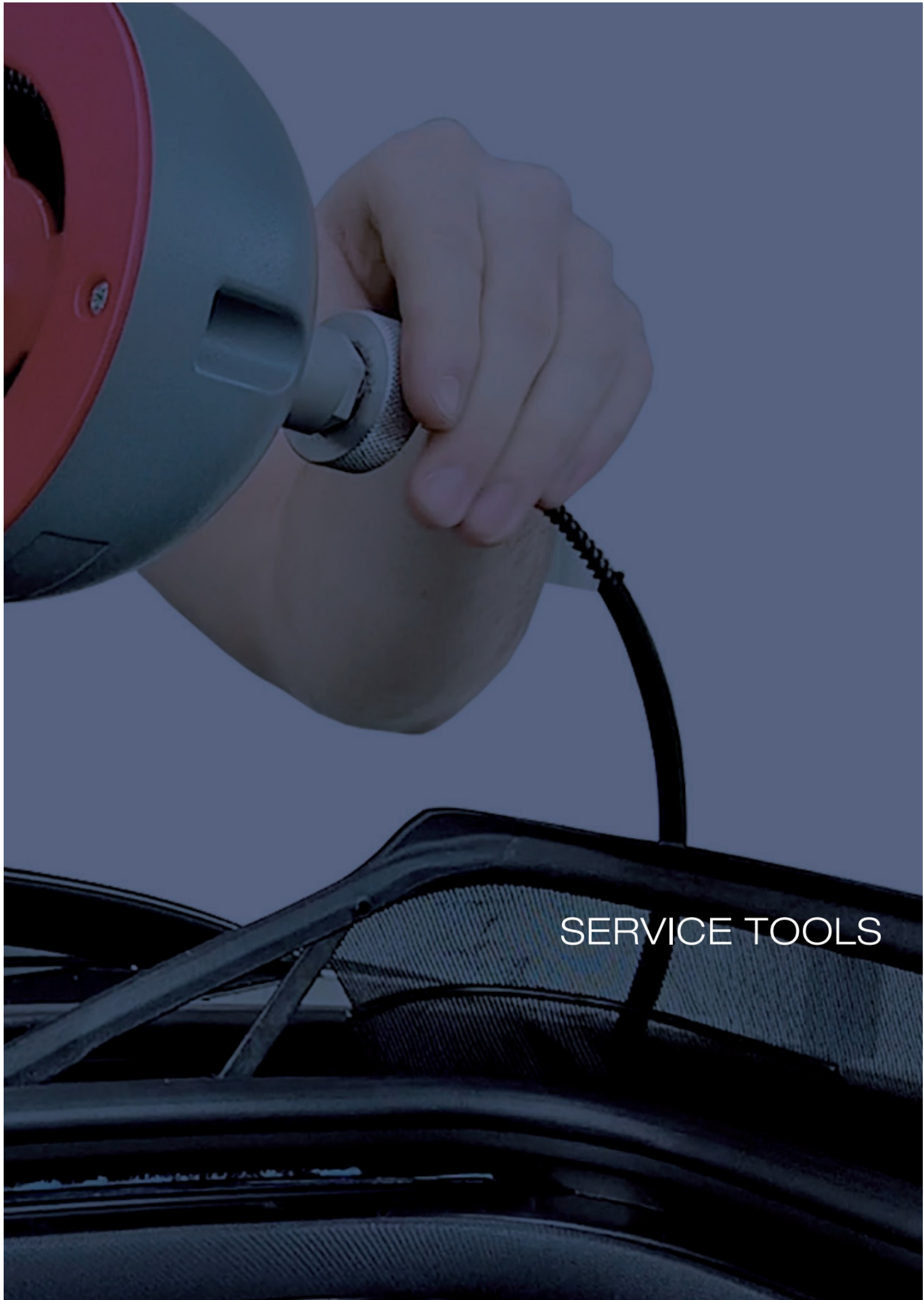

SERVICE TOOLS



TABLE OF CONTENTS

Lifting table WS Lifter 1.4T	179
Water Drain Cleaning Tool WDT-250	180



LIFTING TABLE FOR BATTERIES & MOTORS

The table can be extended to a height of 1.8 m and tilted in the transverse and longitudinal axes. This flex-table technology ensures the perfect positioning of motors and electric vehicle batteries.



MAXIMUM LOAD
1,4 TONS

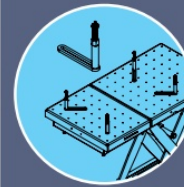

HEIGHT ADJUSTABLE
FROM 800 - 1800 MM

TABLE EXTENSION
FROM 1830 - 2130 MM



HOLE PATTERN
SURFACE
100 X 100 MM



LATERAL INCLINATION
OF SURFACE +/- 4.5

HEIGHT INCLINATION
OF SURFACE +/- 1

4 SWIVEL CASTORS
WITH LOCKING BRAKE

WS Lifter 1.4T

WS Lifter 1.4 T | pneumo-hydraulic

Item no. N851025

Item no. 851025 **Lifting Table FNK4A - Ford version**

Tech. data



201 cm
6' 7"

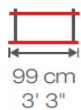

99 cm
3' 3"



80 cm
2' 7"



180 cm
6'



1.400 kg
3.080 lbs



600 kg
1320 lbs



2,0 x 1,0 x 0,8 m
6.5' x 3'3" x 32"



UNE-EN
1570-1:2012+A1



JIGS Adapter Kit*

Item no. 851026 |

Load capacity
600 kg max.



7-piece adapter kit with extension bits for different motors and gearbox height settings. Service and maintenance work can be carried out in a process-safe manner.

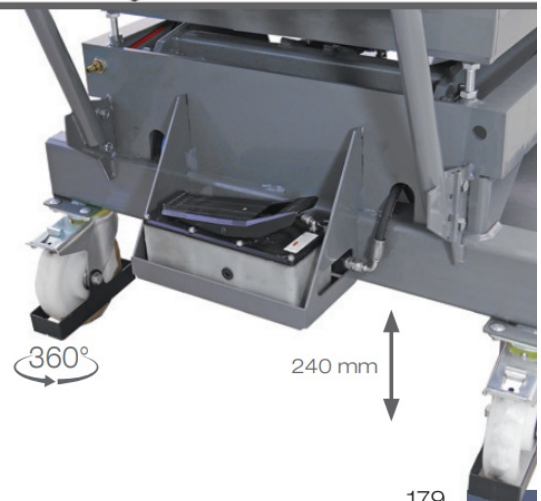

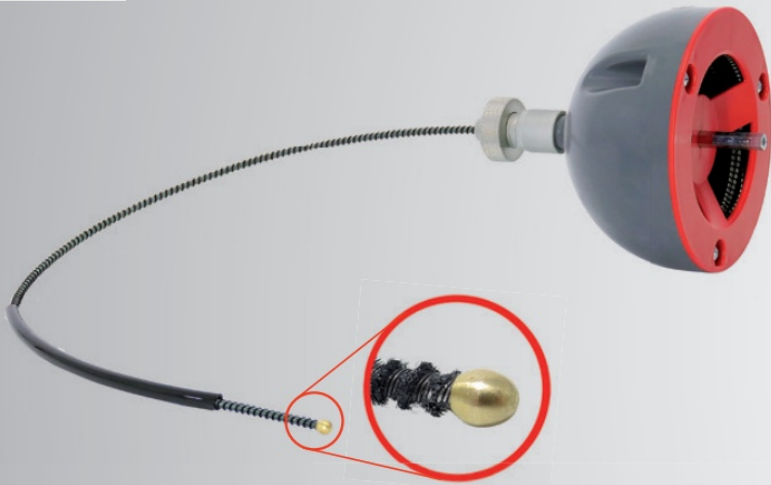

CLEANING OF WATER DRAINS ON THE SUNROOF

FOR ALL
COMMERCIALY
AVAILABLE CORDLESS
SCREWDRIVERS

WATER DRAIN CLEANING TOOL

The WDT-250 cleaning device is used to clean the water drains on the sunroof. Dirt caused by leaves or other residues can be easily removed. The tool consists of a wire holder with a cap for the attachment of a cordless screwdriver. The cleaning shaft is a flocked special shaft with a protective cap.

WDT-250

WDT-250 Water Drain Cleaning Tool

Item no. 801110

FULFILMENT OF THE LATEST TECHNICAL REQUIREMENTS

The material is so elastic that it can be used in the new, tighter, successive radii

INVESTMENT IN THE FUTURE

Cleaning can be offered to the customer as an additional service.



Scope of delivery:

- 1x basic unit with wire shaft container
- 1x special wire shaft flocked 250 cm
- 1x protective hose
- 1x instruction manual

REQUIREMENTS FOR CORDLESS SCREWDRIVER

Drill chuck	RPM	Torque
min. Ø 10 mm	max. 600 min ⁻¹ (gear 1)	min. 30 Nm max. 60 Nm

VAS 6620A Cleaning Tool

ASE 481 265 01 00

The device was specially developed for use on vehicles of all VW Group brands and thus replaces all applications of the predecessor VAS 6620.
First use Porsche MACAN.

PURCHASE EXCLUSIVELY VIA
VOLKSWAGEN LOGISTIK CENTER KASSEL

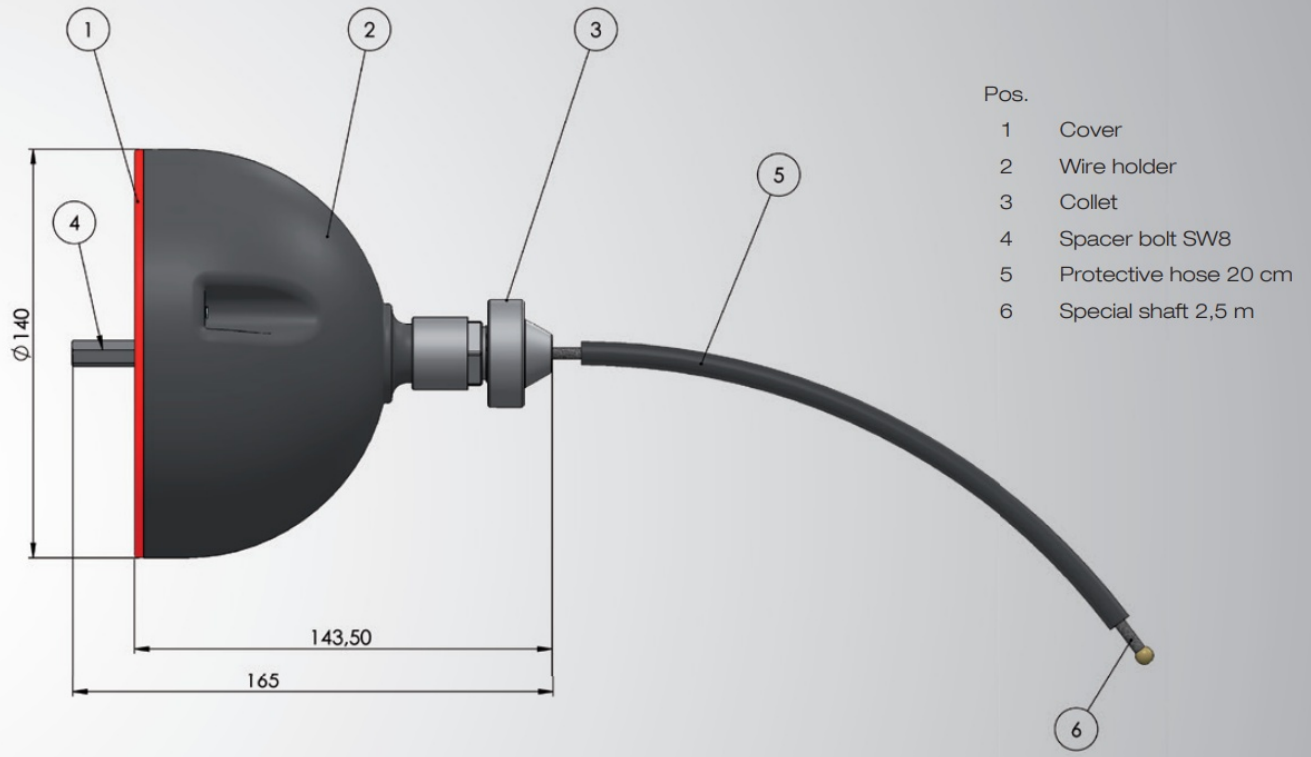

CLEANING BLOCKED DRAINS CAN PREVENT WATER DAMAGE TO THE VEHICLE.



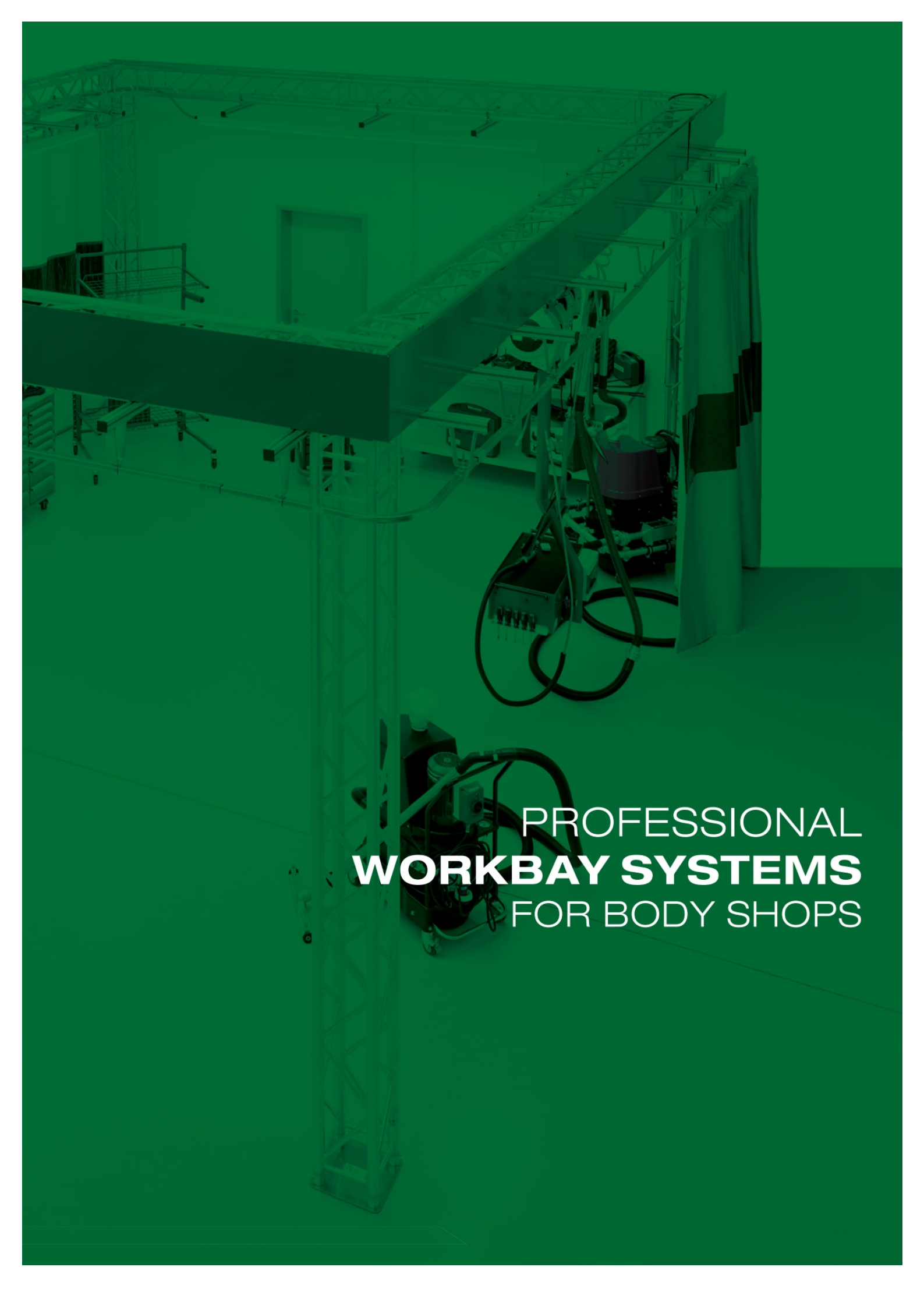

The image shows a professional workbay system for a body shop. It features a metal frame with a lift mechanism. The system is equipped with various tools and equipment, including a lift, a workbench, and a storage cabinet. The entire system is mounted on a metal frame. The background is a plain wall with a window. The text "PROFESSIONAL WORKBAY SYSTEMS FOR BODY SHOPS" is overlaid on the image in white, bold, uppercase letters.

PROFESSIONAL
WORKBAY SYSTEMS
FOR BODY SHOPS



WE ARE THE **FULL-SERVICE PROVIDER** IN THE FIELD OF BODY REPAIR

WELDING TECHNOLOGY

No matter whether MIG/MAG, TIG or spot welding - we have the right welding machine for your specific application.

SEPARATING TOOLS

Saws for all applications in the bodywork - from the universal body saw up to the model for highest demands for power and performance.

OCCUPATIONAL SAFETY

Your safety is close to our hearts. That is why you will find face, eye and ear protection and many other items.

STORAGE SYSTEMS

Mobile storage systems facilitate organisation and tidiness in the Body Shop Workbay.



RIVETING TECHNOLOGY

Our innovative riveting tools from the XSeries product family leave nothing to be desired.

DENT REMOVAL

Dent removal tools for the removal of dents, hail damage and minor damage complete our range.

PAINTING TECHNOLOGY

You will find what you are looking for - from the paint spray gun to the cleaning machine including environmentally friendly paint spray gun cleaner.

VACUUM SYSTEMS

The right vacuum system for grinding and welding work of all common materials can be found with us.

HANDTOOLS

For dent removal, putty filling, clinching or filing - the right tool for every work step.

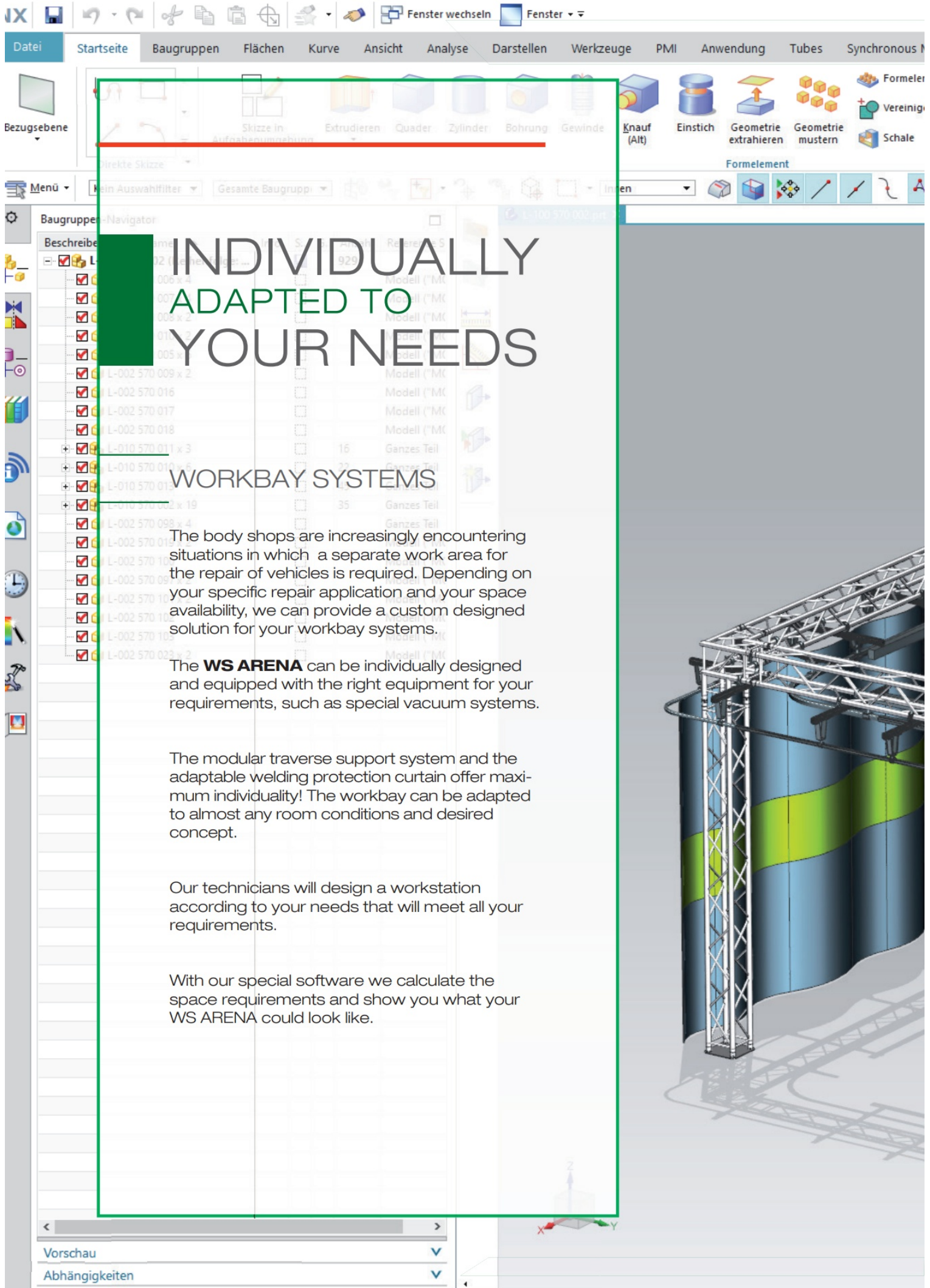

INDIVIDUALLY ADAPTED TO YOUR NEEDS

WORKBAY SYSTEMS

The body shops are increasingly encountering situations in which a separate work area for the repair of vehicles is required. Depending on your specific repair application and your space availability, we can provide a custom designed solution for your workbay systems.

The **WS ARENA** can be individually designed and equipped with the right equipment for your requirements, such as special vacuum systems.

The modular traverse support system and the adaptable welding protection curtain offer maximum individuality! The workbay can be adapted to almost any room conditions and desired concept.

Our technicians will design a workstation according to your needs that will meet all your requirements.

With our special software we calculate the space requirements and show you what your WS ARENA could look like.

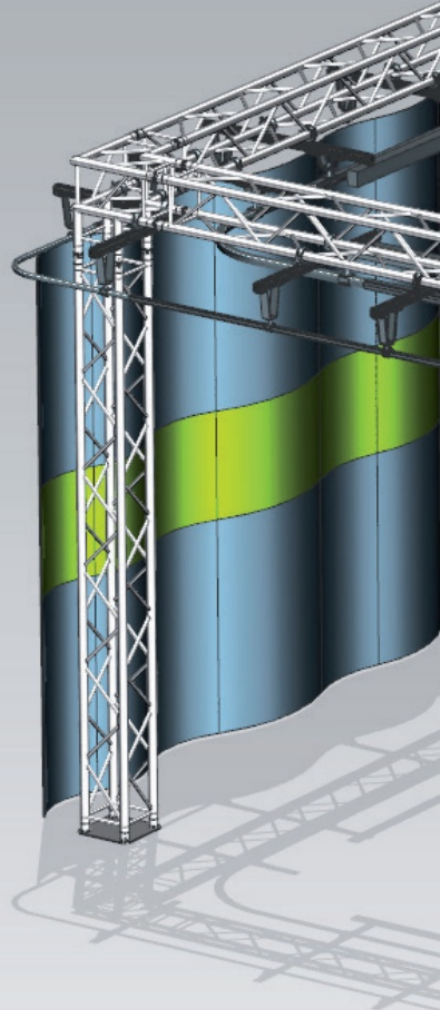

Modeling 3Dconnexion Leitung (Customize)

entwurfsmustern

Kantenverrundung	Fase	Fläche teilen	Weitere	Fläche verschieben	Offset-Bereich	Weitere	Durch Kurven	Weitere
	Formschräge	Körper trimmen		Fläche ersetzen	Fläche löschen		Durch Kurvennetz	Fläche füllen

Synchrone Konstruktion

Oberfläche

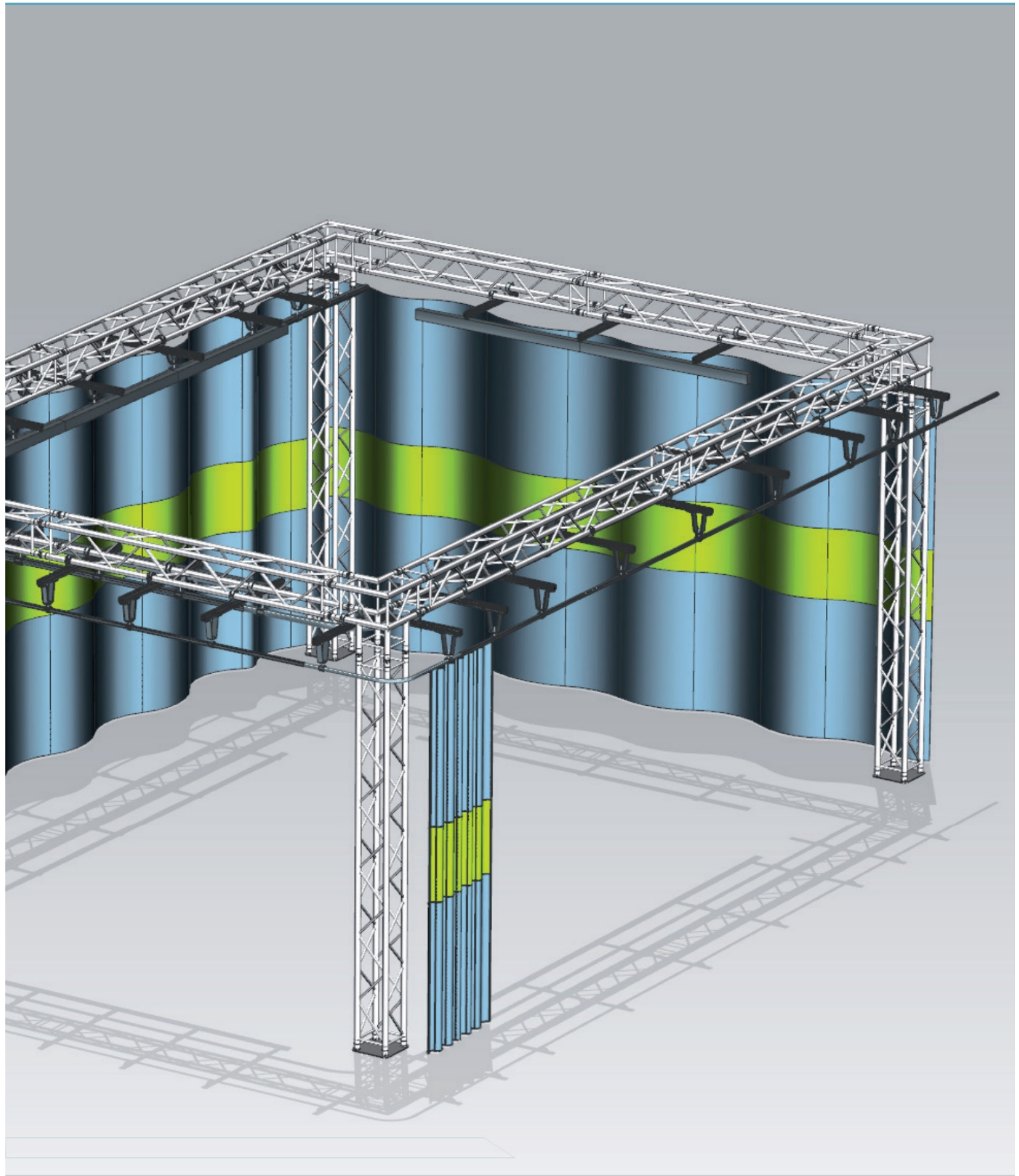

WHY CHOOSE US AS YOUR SOLUTIONS PROVIDER

ADVANTAGES

The welding area is separated from the surrounding area by a specially coated welding protection curtain. The integrated green horizontal strip serves as a visual screen, protecting people outside the workbay from UV radiation, spatters and electric arcs.

The curtain and an LED lighting system are mounted on a high-quality aluminium crossbeam system. The LED lighting system provides optimal lighting conditions and is also characterized by its high energy efficiency and robustness.

Depending on the version, there are either a mobile or two stationary media supply systems. The Mobile Media Supply has been specially designed for use with the workbay systems and offers practical features that ease your workflow and save valuable time.

It goes without saying that we can also supply you with the right vacuuming systems for your application areas, as well as mobile storage systems.

All components of the workbay are characterized by high quality, durability and modern design. In addition, the workbay can be individually adapted to any spatial conditions.

- ✓ SAFETY
- ✓ EFFICIENCY & TIME SAVING
- ✓ HIGH QUALITY
- ✓ ENERGY EFFICIENCY
- ✓ INDIVIDUAL ADAPTATION
- ✓ MODERN DESIGN



360° TOUR



BASIS

Workbay WS ARENA BASIS

Standard dimensions: 6 m x 8 m x 3.5 m

The WS ARENA BASIS is the basic version of the WS workbay systems. In addition to the high-quality aluminium truss support system, it includes energy-saving LED lighting and a special welding protection curtain. The difference between the WS ARENA PLUS and the WS ARENA BASIS is the associated media supply.

In the BASIS version, this consists of two stationary compressed air and power supplies with a robust rubber housing. Optionally, the WS ARENA can be equipped with accessories such as suitable industrial vacuum systems.

Detailed information on all components of the WS ARENA can be found on the following pages.

SCOPE OF DELIVERY

Item no. 881748

- 1 x Aluminium truss system with 4 supports (standard dimensions: 5.5 m x 7.5 m x 3.5 m)
- 1 x LED lighting system
- 2 x Welding protection curtain (standard dimensions: 12.10 m x 2.87 m)
- 2 x Stationary Media Supply

Note on scope of delivery:

Detailed information on the items included in the scope of delivery can be found on the following pages.



PLUS

Workbay WS ARENA PLUS

Standard dimensions: 6 m x 8 m x 3.5 m

The WS ARENA PLUS is the premium version of the workbay systems and also includes the aluminium truss system, energy-saving LED lighting and a special welding protection curtain. It differs from the basic version by the Mobile Media Supply. The Mobile Media Supply was especially designed for the use in the workbays and offers several

practical features. These include drawers, storage cable and hose reels, power outlets, a telescopic arm mount, USB ports and much more!

Detailed information on all components of the WS ARENA can be found on the following pages.

SCOPE OF DELIVERY

Item no. 881749

- 1 x Aluminium truss system with 4 supports (standard dimensions: 5.5 m x 7.5 m x 3.5 m)
- 1 x LED lighting system
- 2 x Welding protection curtain (standard dimensions: 12.10 m x 2.87 m)
- 1 x Mobile Media Supply

Note on scope of delivery:

Detailed information on the items included in the scope of delivery can be found on the following pages.

WELDING PROTECTION CURTAIN

The curtain is suitable for both grinding and welding work. People outside the workplace are protected from UV radiation, welding arcs and spatters.

HEAT PROTECTION AND INSULATION CURTAIN WITH SPECIAL COATING

Material:	glass fabric with one-sided Alufix coating
Material specification:	DIN 1259
Weight per unit area:	DIN EN 1212 7
Fire behaviour:	SeeBG / US Coastgard MED/3.18a + MED/3.13 IMO MSC.307(88)

INTEGRATED GREEN STRIP

Material :	Soft PVC DIN EN ISO 25980
------------	------------------------------

Note on the scope of delivery:

The length of the curtain may vary due to actual building condition. Order lengths are increased to next complete metre.

Standard dimensions:

Height:	2.87 m
Length:	12.10 m

SCOPE OF DELIVERY Item no. 881733

1 x welding protection curtain
excl. carabiner 50 mm (474800)
excl. curtain rolls (881746)



LED LIGHT SYSTEM

Lamps with light-emitting diodes (LEDs) are considered the illuminant of the future and have many advantages over conventional incandescent, halogen or energy-saving lamps.



ADVANTAGES

LIFETIME

LED lamps are very robust and have a service life of up to 60,000 hours. This is three times higher than a fluorescent tube.

HIGH LUMINOSITY DESPITE LOW ENERGY CONSUMPTION

They consume over 50% less energy than conventional fluorescent tubes with the same luminosity. This makes them particularly efficient.

LOW HEAT DEVELOPMENT

Despite their enormous luminosity, LED lamps have very low heat emission.

SHADOW FREE ILLUMINATION

Due to the U-shaped arrangement of the LEDs, the workplace is optimally illuminated.

Beam angle	Flux density per LED unit	Power	Colour temperature
120°	8000 lm / 150 cm	50 W	6500 K daylight white

SCOPE OF DELIVERY

Item no. 881880

10 x LED unit incl. gear tray and accessories



COMPARISON OF BRIGHTNESS

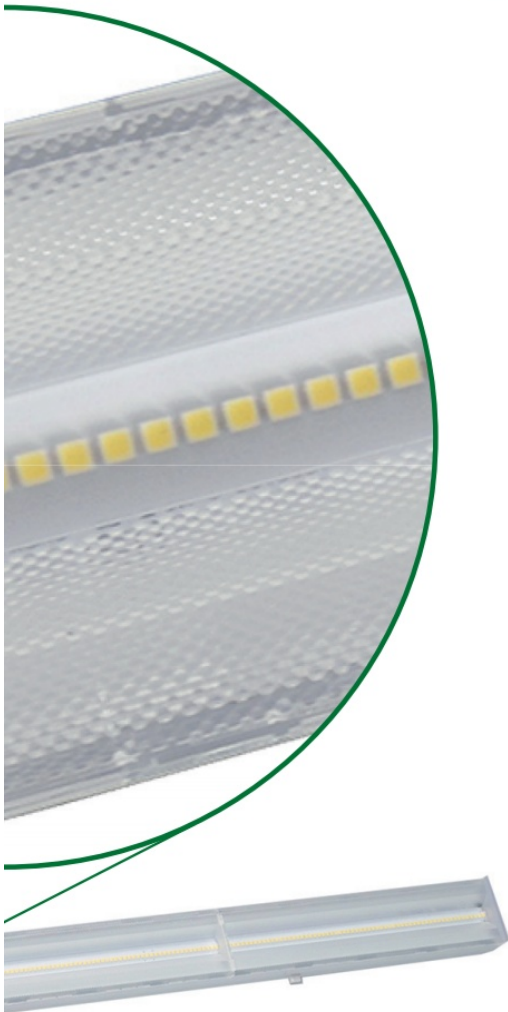



MOBILE MEDIA SUPPLY

Delivery without tools, tablet and telescopic arm.

Developed specifically for the WS ARENA, the Mobile Media Supply offers many features that make your work easier and save you time.

Due to the built-in power and air supply, you can work on every side of the vehicle without the risk of tripping over cables and hoses. The integrated storage systems and a magnetic holder ensure you always have all the documents you need at hand. In

addition, the Mobile Media Supply offers a fixed and rubberized place for a tablet. The built-in holder for a telescopic arm makes welding conditions easier. By pressing the brake switch, the cart stays exactly where you need it.

You will not only work more efficiently, but also more safely!

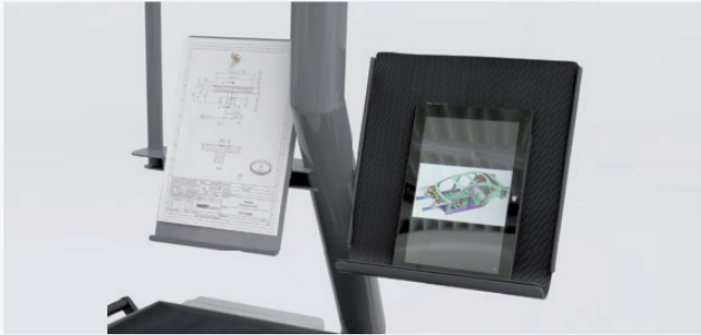
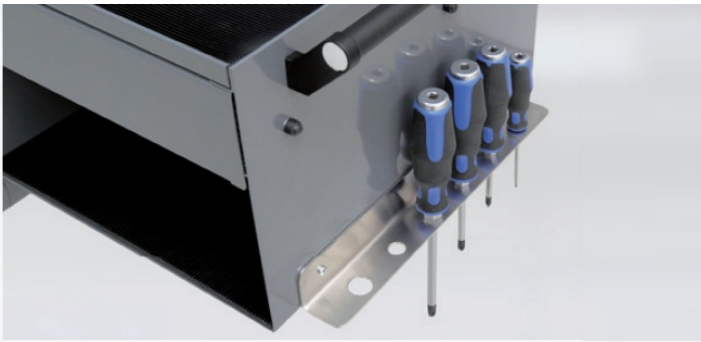

EQUIPMENT FEATURES

Item no. 881797

- 1 x drawer with closing mechanism
- 1 x shelf niche
- 2x cable reel | 15 m | 230 V
- 2x hose reel | 14 m
- 2x compressed air safety connection with push button
- 3x socket | 230 V | CEE 7/3
- 1 x socket | 400 V | CEE 16 A
- 2x USB charging connection
- 1 x media cart brake
- 1 x tablet holder
- 1 x magnetic holder with magnet
- 1 x holder for telescopic arm
- 1 x large storage surface
- 2x handhold to move the trolley



STATIONARY MEDIA SUPPLY

The basic complete package!

Stationary media supply with robust, hard rubber-reinforced housing for space-saving compressed air and energy supply.

The stationary media supply can be attached to any side of the WS Arena. This eliminates tripping hazards caused by cable drums, extension cables or compressed air hoses.

The compressed air safety connection with push button prevents the compressed air hose from being ejected when disconnected. The integrated overload protection protects the stationary media supply from overheating and switches off automatically if necessary.

EQUIPMENT FEATURES

Item no. 881663

- 4 x compressed air safety connection with push button
- 12 x socket | 230 V | CEE 7/3
- 2 x socket | 400 V | CEE 16 A

DUST CLASS H

according to EN 60335-2-69

Annex AA+CC

DGUV 109-001



VACUUM SYSTEM FOR ALU AND CFRP DUSTS

Due to the attached spark trap including 5 m cooling section, the industrial vacuum cleaner is compliant with DGUV regulation 109-001 and is suitable for grinding, cleaning and polishing of aluminium.

Filter combination:

Pre-filter:

Residual dust filter:

Transmittance rate:

dust class M

dust class H

< 0.005 %

APPROVED UTILISATION

- for vacuuming dry, combustible, hazardous dusts; dust class H
- for collection of any dust with all exposure limits*, including dusts hazardous to health - with recirculation of clean air into the working area
- **Dust class H**
(including dust classes L and M)

* AGW- Occupational exposure limit value

SCOPE OF DELIVERY

Item no. 881091

- 1 x mobile vacuum unit with grey hood
filter class M | zone 22 | CE 400 V 16A
- 1 x spark trap (mounted)
- 1 x hose plastic Ø 50 mm | 5 m
with Storz C clutch
- 1 x hose plastic Ø 40 mm | 5 m
with Storz C clutch
- 1 x plastic hose Ø 50 mm | 5 m
with pressure pin

- 1 x transition Ø 50 mm
Storz C clutch to pressure pin
- 1 x curved hand tube Ø 50 mm
- 1 x hand tube stainless steel Ø 50 mm | 1 m
- 1 x floor nozzle cast aluminum body | 50 cm wide
- 1 x crevice nozzle | 30 cm long
- 1 x holder suction arm



DUST CLASS H

according to EN 60335-2-69

Annex AA+CC

DGUV 109-001

NA7-26 MOBILE WET SEPARATOR

ADVANTAGES:

Wet separators are used for the separation of dusts and dust particles of any kind. These are harmlessly bound by the introduction into liquid media and are no longer flammable. They are particularly suitable for aluminum or magnesium dusts. The additionally installed residual dust filter of class H also enables the extraction of CFRP dusts.

- accurate indication of differential and negative pressure
- easy emptying & cleaning
- easy filter change
- strong performance despite compact dimensions
- effective unit cooling
- optical level monitoring with additional level sensor

SCOPE OF DELIVERY

Item no. 881760

- 1 x separator unit NA7-26
- 1 x hose 5 m
- 1 x hand tube
- 1 x curved hand tube
- 1 x industrial floor nozzle
- 1 x crevice nozzle
- 1 x 10 m power cord
- 1 x accessory box
- 1 x hose holder | stainless steel, mounted

- 1 x additional equipment | push handle
- 1 x cable holder | stainless steel, mounted

DUST CLASS M

according to EN 60335-2-69

Annex AA+CC

DGUV 109-001



VACUUM SYSTEM FOR ALUMINUM DUSTS

Due to the attached spark trap including 5 m cooling section, the industrial vacuum cleaner is compliant with DGUV regulation 109-001 and is suitable for grinding, cleaning and polishing of aluminium.

Filter combination:

Pre-filter:

dust class M

Transmittance rate:

< 0.005 %

APPROVED UTILISATION

- Combustible as well as non-combustible dust with exposure limits* $\geq 0.1 \text{ mg/m}^3$ with recirculation of clean air into the work area
- **Dust class M**
(including dust class L)

* AGW- Occupational exposure limit value

SCOPE OF DELIVERY

Item no. 881090

1 x mobile vacuum unit with grey hood
filter class M | zone 22 | CE 400 V 16A
1 x spark trap (mounted)
1 x hose plastic \varnothing 50 mm | 5 m
with Storz C clutch
1 x hose plastic \varnothing 40 mm | 5 m
with Storz C clutch
1 x plastic hose \varnothing 50 mm | 5 m
with pressure pin

1 x transition \varnothing 50 mm
Storz C clutch to pressure pin
1 x curved hand tube \varnothing 50 mm
1 x hand tube stainless steel \varnothing 50 mm | 1 m
1 x floor nozzle cast aluminum body | 50 cm wide
1 x crevice nozzle | 30 cm long
1 x holder suction arm



DUST CLASS M

according to EN 60335-2-69

Annex AA+CC

VACUUM SYSTEM FOR STEEL DUSTS

ADVANTAGES

- Modular system - modular construction to meet higher operational or legal requirements can be retrofitted at any time without problems
- No need to buy expensive filter bags all the time
- Convenient and quick foot lever emptying

APPROVED UTILISATION

- Combustible as well as non-combustible dust with exposure limits* $\geq 0.1 \text{ mg/m}^3$ with recirculation of clean air into the work area
- **Dust class M** (including dust class L)

* AGW- Occupational exposure limit value

SCOPE OF DELIVERY

Item no. 881089

- 1 x mobile vacuum unit with grey hood filter class M | zone 22 | CE 400 V 16A
- 1 x hose plastic $\varnothing 50 \text{ mm}$ | 5 m with Storz C clutch
- 1 x hose plastic $\varnothing 40 \text{ mm}$ | 5 m with Storz C clutch
- 1 x plastic hose $\varnothing 50 \text{ mm}$ | 5 m with pressure pin

- 1 x transition $\varnothing 50 \text{ mm}$ Storz C clutch to pressure pin
- 1 x curved hand tube $\varnothing 50 \text{ mm}$
- 1 x hand tube stainless steel $\varnothing 50 \text{ mm}$ | 1 m
- 1 x floor nozzle cast aluminum body | 50 cm wide
- 1 x crevice nozzle | 30 cm long
- 1 x holder suction arm



TELESCOPIC ARM FOR MOBILE VACUUM SYSTEMS

The extractor arm enables the user to work efficiently with the greatest possible freedom of movement. The extraction plate ensures that dust and chips can be optimally collected. Via the C-clutch, the telescopic arm can be connected to the vacuum system directly or also via an extension hose.

For easier handling, the arm can be attached to the Mobile Media Supply.

Suitable for the following systems:

- 881090 - Vacuum system for aluminum dusts
- 881091 - Vacuum system for ALU and CFRP dusts
- 881889 - Vacuum system for steel dusts
- 881760 - NA7-26 Mobile wet separator
(only in combination with mobile media trolley 881092)

EQUIPMENT FEATURES

Item no. 881092

Outreach:	outreach 2000 mm
Extraction funnel:	extraction plate 420 x 260 mm stainless steel
Attachment:	square tube with star grip



CAREMASTER

MOBILE FUME EXTRACTION SYSTEM

Mains connection	Power	Welding fume filter		Adhesive fume filter			Extraction system performance	Sound pressure level	Negative pressure
		M5	F9	M5	H13	Activated carbon cassette			
400 V (16A)	2.2 kW	M5	F9	M5	H13	Activated carbon cassette	3500 m ³ /h	73 db(A)	250 mbar

Mobile extraction and filtering unit for the extraction and filtering of fumes and adhesive vapors generated during thermal joining and cutting of metals and plastics. The unit is equipped with two hose extraction arms with internal joints. The innovative

spring support inside the extraction arms allows the arms to be easily adjusted to any position. The suction hood with integrated throttle valve can be swivelled in any direction.

SCOPE OF DELIVERY

Item no. 881752

- 1 × filter unit type SF II IFA
- 2 × hose arm 3 m
- 1 × power cable 5 m
- 1 × pre-filter mat M5
- 1 × particle filter F9
- 1 × particle filter H13
- 1 × activated carbon cassette

ACCESSORIES & SPARE PARTS FOR VACUUM SYSTEMS

CAREMASTER MOBILE FUME EXTRACTION SYSTEM

PARTICLE FILTER F9 Item no. 881822	ACTIVATED CARBON FILTER Item no. 881821	PARTICLE FILTER H13 Item no. 881820	PRE-FILTER MAT M5 Item no. 881810
			10 PCS. 
PROTECTION GRILLE Item no. 881813	PE-BAGS Item no. 881812	SUCTION HOOD Item no. 881811	FRAME FOR M5 Item no. 881878
	4 PCS. FOR THE DISPOSAL OF FILTER ELEMENTS	INCL. THROTTLE VALVE 	

NA7-26 MOBILE WET SEPARATOR

FILTER CARTRIDGE Item no. 881758	MOISTURE TRAP Item no. 881759
DUST CLASS H 	

VACUUM SYSTEMS FOR STEEL, ALU AND CFRP DUSTS

DISPOSAL CONTAINER D1-D2 Item no. 881111	BAG FILTER M Item no. 881112	RESIDUAL DUST FILTER H13 Item no. 881113
		



BODY SHOP MANAGER

ADVANTAGES:

- Mobile storage for bodywork and automotive add-on parts
- Clear storage of parts in the workshop during the repair process
- Safe storage and protection against damage
- The use of the tray minimizes the loss of parts and their interchangeability
- Easy and quick assembly

SCOPE OF DELIVERY Item no. 881100

- 1 x shelf (basic version)
- 3 x storage basket
- 4 x swivel castor with parking brake
- 4 x additional arm
- 4 x foam cover for additional arm
- 1 x storage system for doors, tailgates, engine hoods, etc.

RUBBER INSERT FOR STORAGE BASKETS 1000 x 550 mm Item no. 881194	ADDITIONAL ARMS FOR BODYSHOP MANAGER 500 x 70 x 25 mm 2 pcs. Item no. 881180
	
FOAM COVERS FOR ADDITIONAL ARMS Ø 60 mm L = 450 mm 2 pcs. Item no. 881181	
	

NOTIZEN

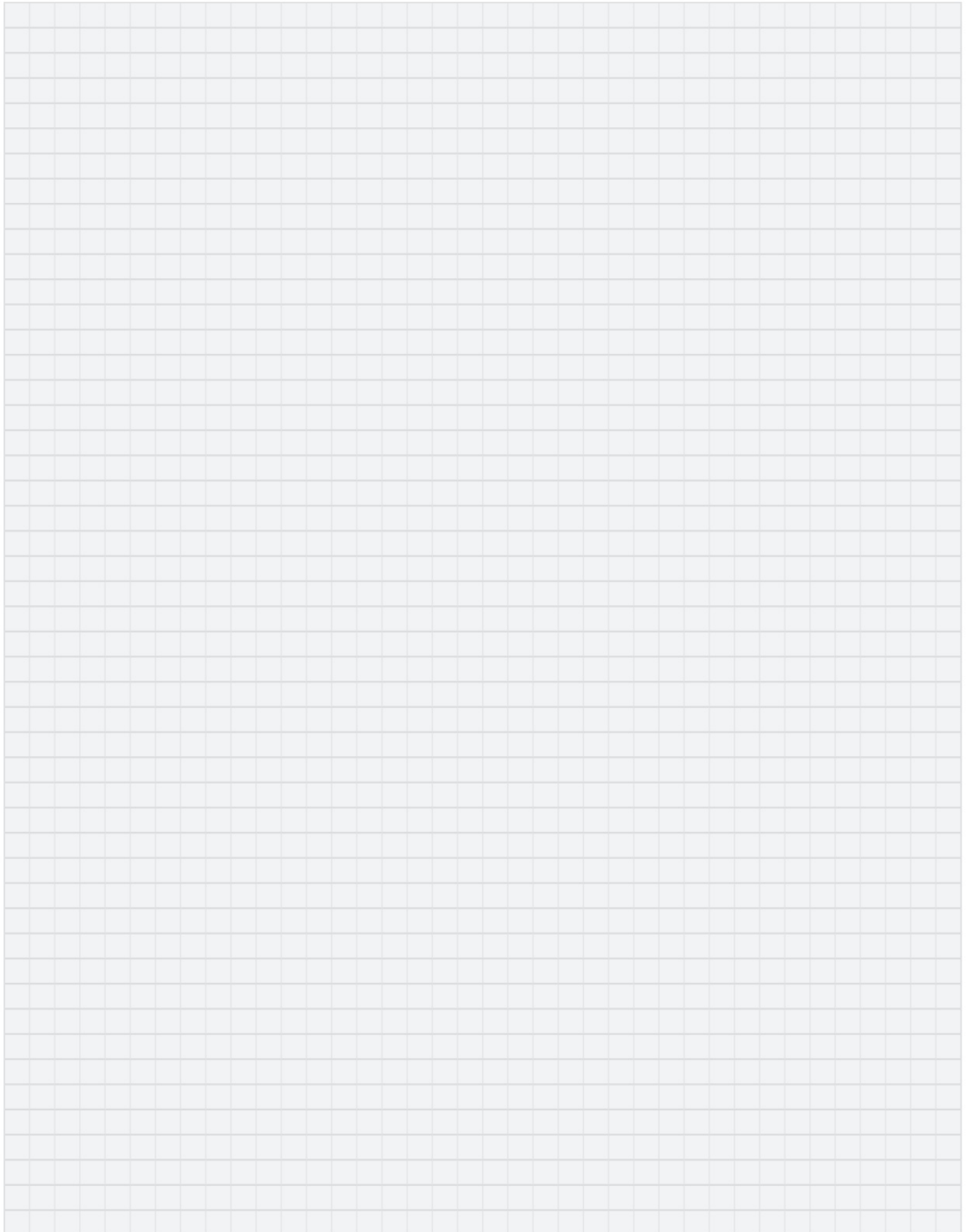

NOTIZEN

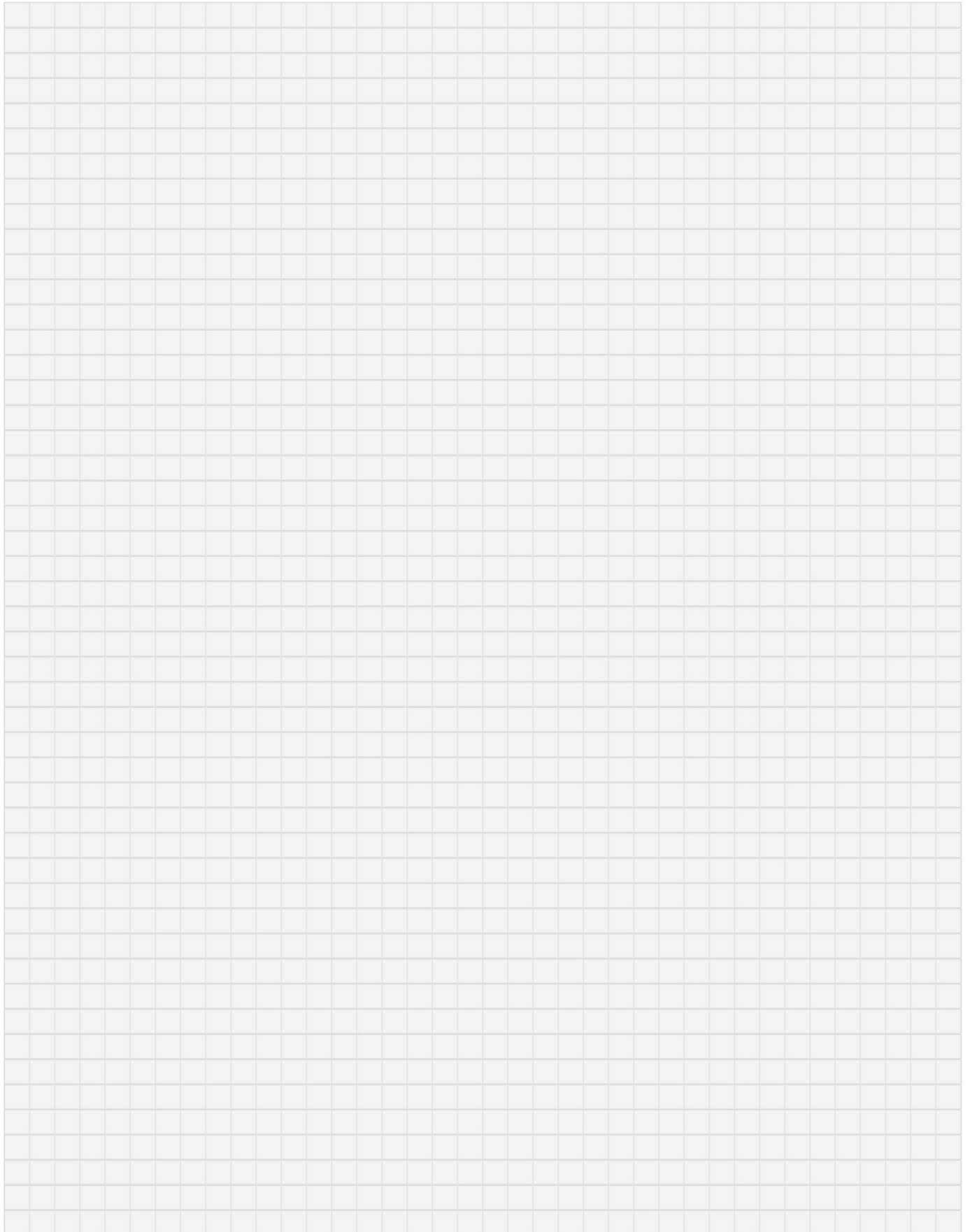

NOTIZEN

